

# INSTRUCTIONS FOR FITTING OUT THE *ECHO* CROSS-SECTION MODEL

AN ILLUSTRATED MANUAL

TEXT AND ILLUSTRATIONS BY  
DAVID ANTSCHERL

MODEL & PHOTOGRAPHS BY  
GREG HERBERT

FITTING OUT THE *ECHO* CROSS-SECTION

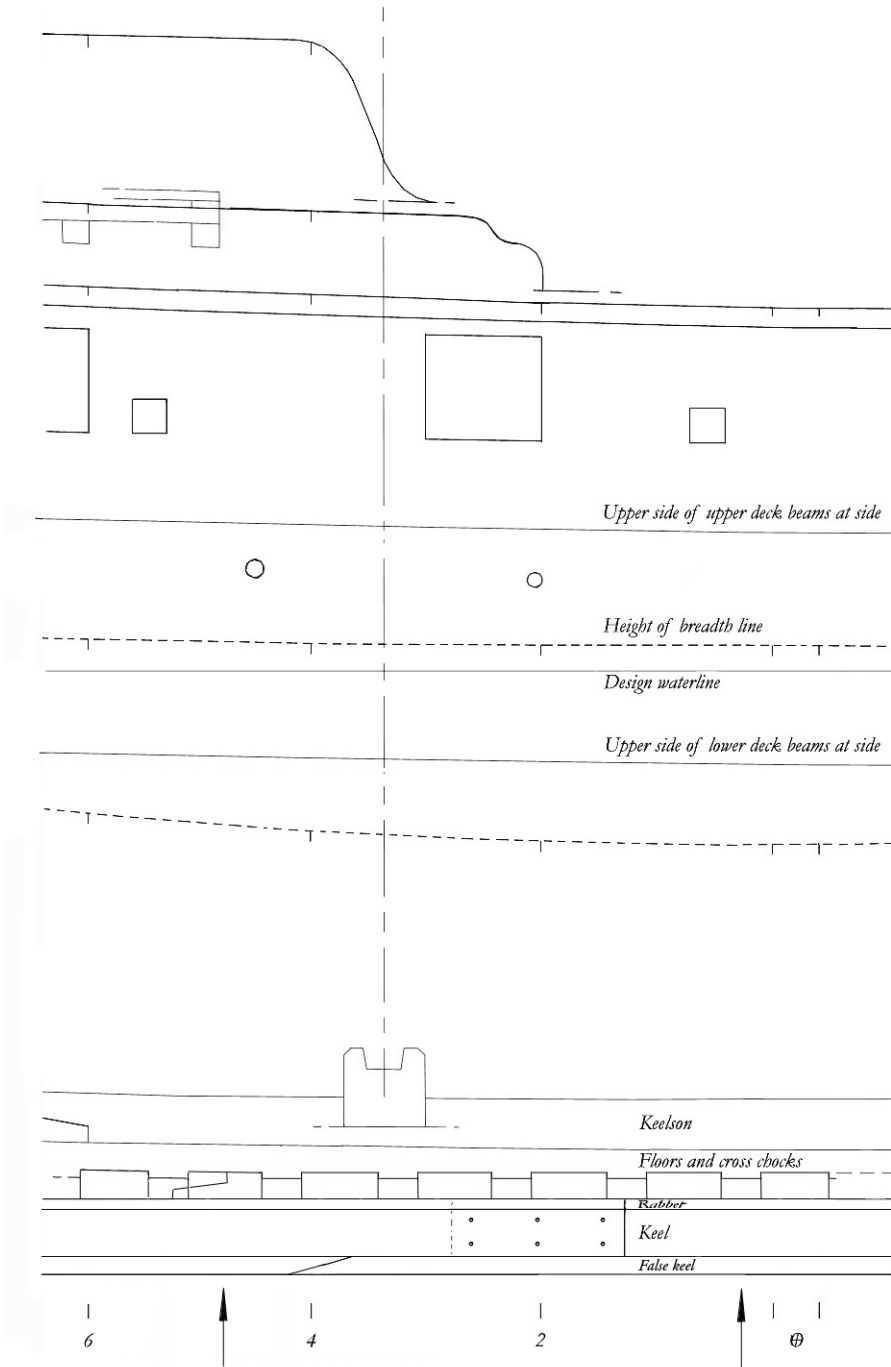

## INTRODUCTION

Welcome to fitting out your framed cross-sectional *Echo* model. This guide will describe all the fittings that were found in that part of the original ship. We will take you step by step through completing the planking, internal structure of the lower and upper decks with their associated beams, knees, carlings and ledges, as well as the ship's well and pumps. You will also construct the support structures for the main mast, the various bitts and their fittings, as well as the fore edge of the quarter deck.

This exercise will prepare you to build a complete model of a mid- to late-eighteenth century British naval vessel. You will learn a number of skills and techniques that are required to successfully complete such a project. Hopefully the confidence you will gain as you progress through this instructional manual will encourage you to scratch-build the model of your choice.

I have frequently mentioned the vast range of subjects that the modelmaker can choose from. Many of the plans in the collection at Royal Museums Greenwich (RMG) – formerly the National Maritime Museum (NMM) – may be viewed on line<sup>1</sup>. Rather than yet another model of *Victory*, the plethora of ship types and sizes to choose from and to build a truly unique model is amazing. I encourage you to look at the possibilities available when considering your next model.

Now it is time to turn the page and begin. Many readers have or will obtain a wood package from which to construct the model to completion<sup>2</sup>, but others may wish to cut their own wood from stock on hand. Either way, enjoy the journey!

David Antscherl and Greg Herbert

June 2015

---

<sup>1</sup> Search: Royal Museums Greenwich > Collections > Ship Plans

<sup>2</sup> Currently (2015) available from Crown Timberyard, at [crowntimberyard.com](http://crowntimberyard.com)

FITTING OUT THE *ECHO* CROSS-SECTION

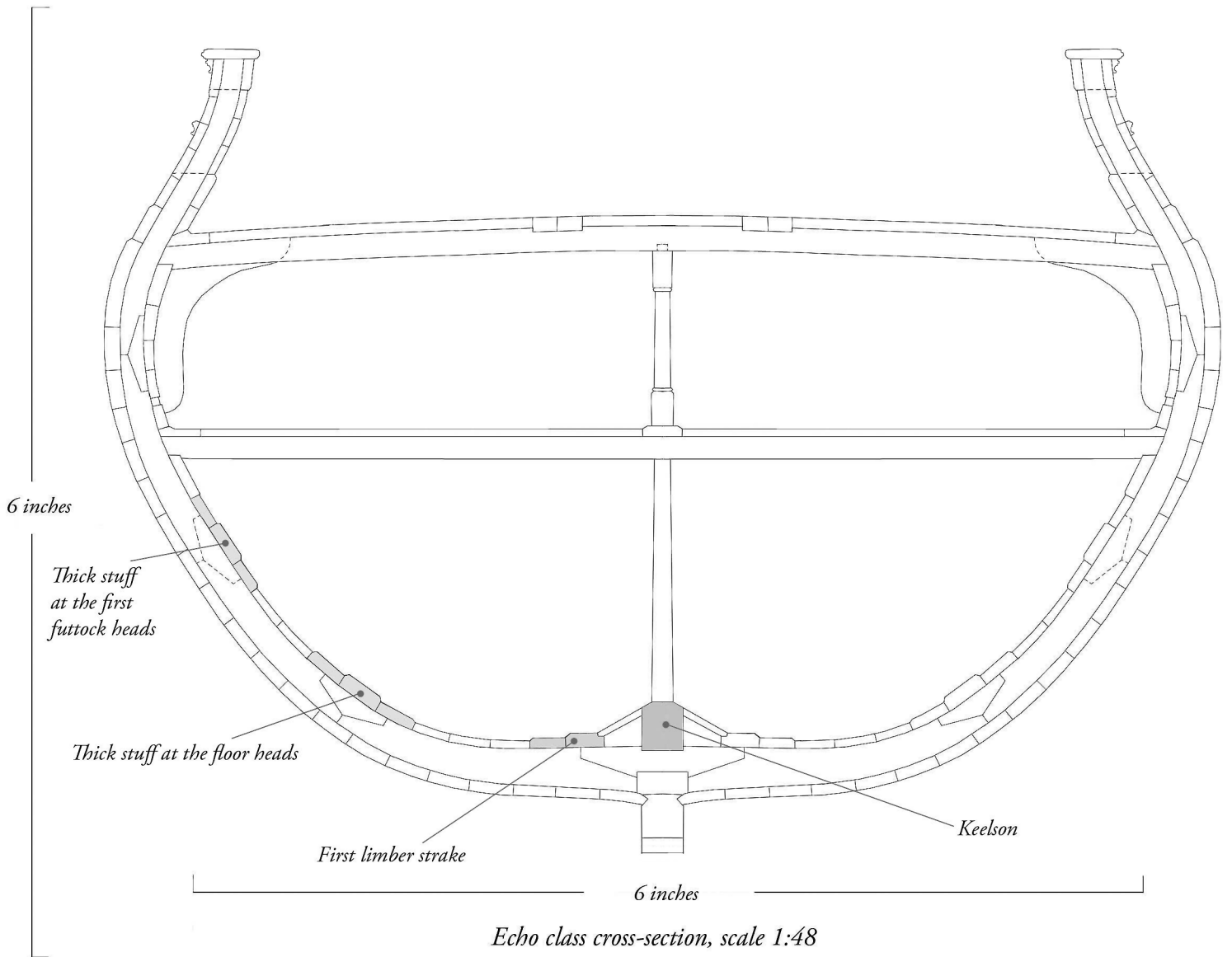

## FITTING OUT THE HOLD: THE CEILING

Once you have completed the *Echo's* framing it is time to put flesh on the bones, so to speak. The first order of business is to add the *keelson*. This, according to the contract, is 12" square. It is scored on the underside to sit down on the floor timbers by  $\frac{7}{8}$ ". The cross-chocks are also scored, as shown on the cross-section. Note that the upper corners of the keelson are beveled off as shown on the drawing (left). Every other floor timber is bolted through from the upper side of the keelson to the underside of the main keel with a bolt  $1\frac{1}{8}$ " in diameter. Practically, all you need do is drill and insert a bolt head on the upper side of the keelson if you wish to show this detail. The bolt head should be about  $1\frac{1}{2}$ " in diameter, or  $\frac{1}{32}$ " full size.

Now let us move on to the planking in the hold. The first internal strakes of planking are the *limber strakes*. They are placed 11" out from the sides of the keelson (at left). Each plank is  $4\frac{1}{2}$ " thick and 12" wide. They will need a rabbet cut into the inner edges, as shown on the illustration. These rabbets will hold the limber boards in place. Note that, as a rule, wherever there is a change in thickness of planking, the step so formed is always beveled off, leaving no sharp corners. Note also that, as the hull shape is virtually parallel along the cross-section, no tapering of these planks should be required.

The second strakes to be added are those immediately outside the limber strakes, also shown. These are 10" wide by 3" thick.

Next is the *'thick stuff'* at the floor heads over their joints with the second futtocks, reinforcing them. There is a 4" thick plank 14" wide, on each side of which are two planks, each 3" thick and 12" wide.

A similar reinforcement is run along the line of the first futtock head joints. Here the heavier plank is 4" by 13", and the two planks each side of this are 3" by 10".

Between these bands, planking called *foot-waling* of 2" thick plank fills the spaces (unshaded). There should be space for three planks on the bottom of the hold and two between the floor and first futtock head thick stuff. Adjust the plank widths so that they neatly fill the remaining spaces.

The next task is to cut, shape and fit the *lower deck clamps*. These are substantial planks, as shown just below the lower deck beam ends. There is a discrepancy with the contract, which calls for two strakes. However, with the position of the thick stuff over the first futtock heads, there is only space for one strake. I would make this single strake to the scantling of the upper of the two strakes called for, which is 3" thick by 13" wide. However cut this a little wider, because the clamp is not rectangular in section.

The upper edge is dubbed back to horizontal. You can do this with a small plane or chisel while the clamp is held firmly in a vise. Note that this piece is relatively straight over the short cross-section. I would cut the blank over-length for safety. It will be trimmed back after it is installed on your model.

One method to achieve the correct angle is as follows: cut a piece of card at the angle shown in the diagram (at right). This, oriented correctly relative to the clamp, will guide your plane or chisel.

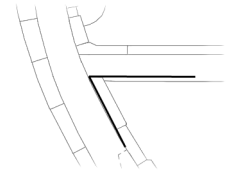

The next challenge is to ensure that the clamp is installed at the correct height inside the framing. Check the illustration on page 2. You will see a line marked 'upper side of lower deck beams at side'. From this you will need to draw a line parallel and below this, as follows. First, measure down from this line by 6" in scale, or  $\frac{1}{8}$ " full size. (I find it much easier to work with a scale rule, rather than have to 'translate' into fractions of full-size inches.) Now, looking at the cross section you will see that the beam is let down into the clamp by 1". Therefore the top edge of the clamp is 5" below the upper edge of the deck beam. Draw this line on the sheer plan.

Next, measure the height on the drawing from the baseline (bottom of the false keel) to the top of the clamp at the dead flat. Transfer this to both sides of the model, which should be firmly attached to the baseboard and plumb upright. Repeat this at Station 5.

Now fit the clamp to the model. The uppermost strake of ceiling plank may need trimming back slightly so that the clamp sits at the correct level. It is most important that the clamp be installed at the correct level on both sides, as so many of the remaining structures depend on this. Glue in the clamps and trim the ends flush to the frames. As the contract does not specify the fasteners, I would use tree-nails in the usual diagonal pattern.

For a change of pace, next make the *limber boards*. Shown on the cross-section, these cover and protect the limber channel. They are  $2\frac{1}{2}$ " thick. They are each in sections 3' 0" long, with a half round cutout at each end large enough for a sailor to grasp for removal and replacement (see diagram). Note that both long edges are chamfered or angled. A similar method to the one you used for the top of the lower deck clamp may be used to shape the boards before cutting them into separate lengths. Do not install these boards yet, though!

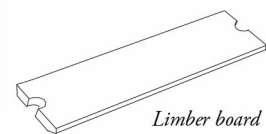

Next we will begin to fit out the section of the ship's hold. The first order of business will be the *main mast step*. Its position is shown on your sheer plan. The step is a substantial baulk of wood that sits across the keelson. It is 1' 1" deep over the keelson and 1' 8" wide. The length is such that it fits between the stanchions of the well (see next page, upper right). Cut and shape it as shown. The corners are chamfered off and there is a square mortise for the mast. If you wish to add more detail (although it will be completely hidden), see Volume I, *The Fully Framed Model*, section 4.28<sup>1</sup>.

### LOWER DECK FRAMING

Before making the lower well, the *lower deck beams* need to be made and positioned. These beams are 6" deep and 7½" wide. They are quite straightforward to make, as they have no round-up.

### THE WELL

Now the *well* of the ship can be built. We will omit all its internal detail. However, should you wish to add this, refer to Volume I, *The Fully Framed Model*, which gives all the detail you will ever want or need. (See sections 5.14 to 5.18 and 6.34 to 6.37.) Assuming that you will make only the visible detail of this structure and the shot locker, proceed as follows:

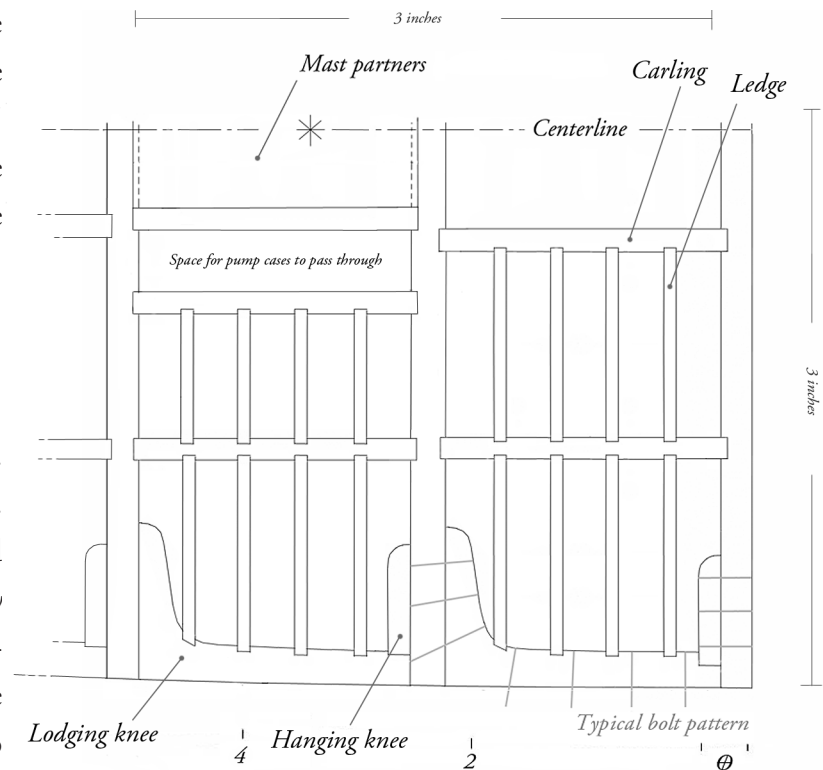

Mark out the position of the well walls in your model. Refer to the drawing on the next page. Now take some stiff card and, by trial and error, make a template of the bottom of the hold to fit across the keelson, limber strakes and ceiling planks. It will probably take several attempts, refining each from the previous, before getting a good fit. Card is cheap and easy to cut; wood is neither! I use card templates extensively in my own work. It is time and effort well spent.

<sup>1</sup> The *Fully Framed Model*, *HMN Swan Class Sloops 1767-1780* in four volumes, SeaWatchBooks PLC, Oregon [www.seawatchbooks.com](http://www.seawatchbooks.com)

FITTING OUT THE *ECHO* CROSS-SECTION

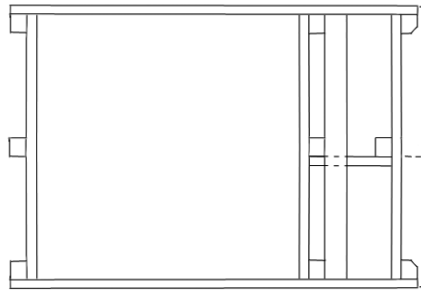

*Plan view*

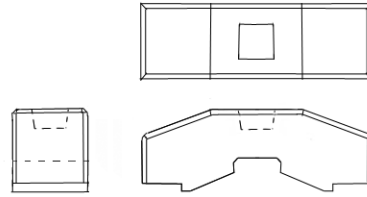

*Main mast step*

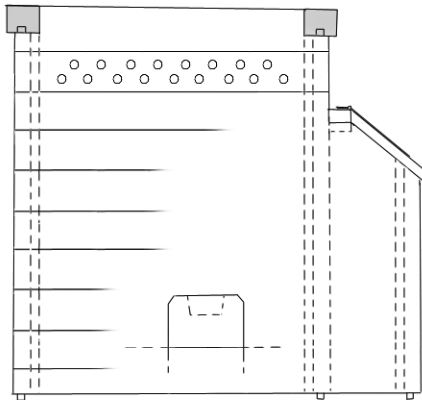

*Side elevation*

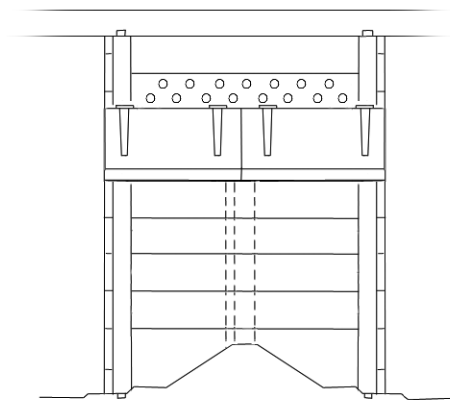

*Forward end elevation*

*Profile of bilge approximate only*

*Echo lower well and shot locker*

*Measurements will vary slightly; measure from your own model!*

6 inches

You can now construct the lower well as per the illustrations and fit it into the model. The stanchions are 4" square and the planking 2" thick. Measure the stanchion lengths from your model: they may vary slightly from my drawing. Each stanchion tenons into the deck beams above and the ceiling below. You could simply use short dowels for this, as they will be hidden. Chamfer the outside corners of all the stanchions. I would make the planks about 10" wide. Ideally the hinges for the shot locker lids should be made of copper or brass and silver soldered (see page 22), but they can easily be made with card for the straps and trenail material for the hinge knuckles. Paint them black.

One small contentious point: there must have been an access door to the lower well, but this is not shown on any draught I've studied. If you opt to show such a door, its logical location is on the aft side to starboard, between the two stanchions there. Once the mast step and lower well are installed, the limber boards that you have already made can be put in place.



As the model proceeds, you will find that each part will be dependent on others. A case in point is the ship's pumps. The pump tubes, while vertical as seen from the side, are angled outward when viewed from fore or aft. While these will not be fully detailed on this model, the upper ends of the tubes will still need to appear at the correct angle where they emerge from the upper deck. In order to arrange these, the upper deck clamps and beams will need to be made and temporarily fitted and the main mast partners constructed first.

### INTERNAL PLANKING BETWEEN DECKS

The *upper deck clamps* are in two strakes. The upper is 14" by 4", the lower one 11" by 3" thick. Make sure that you install these at the correct height. The procedure is the same as for the lower deck clamps, so refer to the illustration on page 2. If you look at the cross-section shown on page 4, you will see that the clamps taper across their width. This is more easily accomplished on the workbench before you glue and treenail them in place.

### UPPER DECK FRAMING

The *upper deck beams* are 9" sided and 7" molded. They round up 5½". There are three beams in the cross-section, two of which have beam arms fitted. Mark out the shape of the beams on 9" stock and saw them out. I find it useful to cut a piece of scrap to the same curve and rubber cement sandpaper to both pieces, making a convex and concave sanding block with which to smooth the sawn beams to size. Make the blanks a little over-length to allow for trimming. As the cross section will show this detail, add the scores for the binding strakes by 1" as shown below. There is also a central mortise for

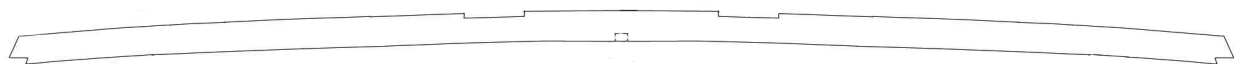

*Upper deck beam pattern*

the supporting pillar that will be made later. Note that the beam is also let down on the clamp.

The *beam arms* can be constructed now as well. These reinforce the beams against the forces exerted on the ship's structure by the main mast and its sails. The drawing overleaf shows you how these are fitted to the sides of their beams. Cut them from stock about 10" thick and sand them on the curved blocks until they are 7" thick. Then carefully mark and cut the tabled joints. Note that the inner ends of the forward beam arms will abut the carlings that define the main hatchway. The hatchway will be 4' 6" wide, and the carlings 6½" wide and 5" deep. Mark these out carefully on the beams. Do not install the beams permanently yet. If carried out carefully, this work should keep you occupied for a while.

In this class of ship there was no upper well. I had thought this a standard feature, but research revealed that there is none. There are other examples of 16-gun ships of the late 18th century without this feature. This being the case, the lower well needs some form of ventilation, or rot and foulness would soon set in.

I do not have the definitive answer as to how this was achieved, but a series of 2" diameter holes around the upper part of the lower well would be appropriate. Please refer to the drawings on page 8. The holes needed to be small enough that debris would not enter, but sufficient ventilation on all sides was necessary. In a conventional situation the top of the lower well was open and the upper one, above, had 'walls' around all four sides consisting of louvers. Permanently install the well.

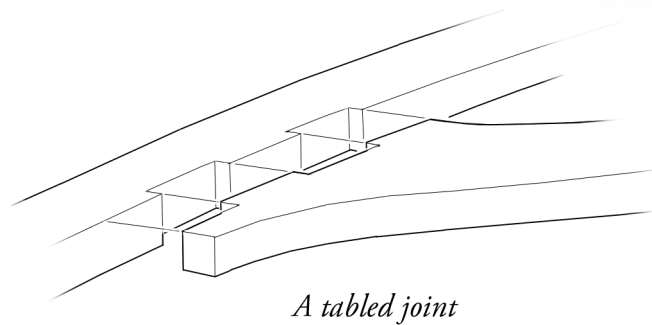
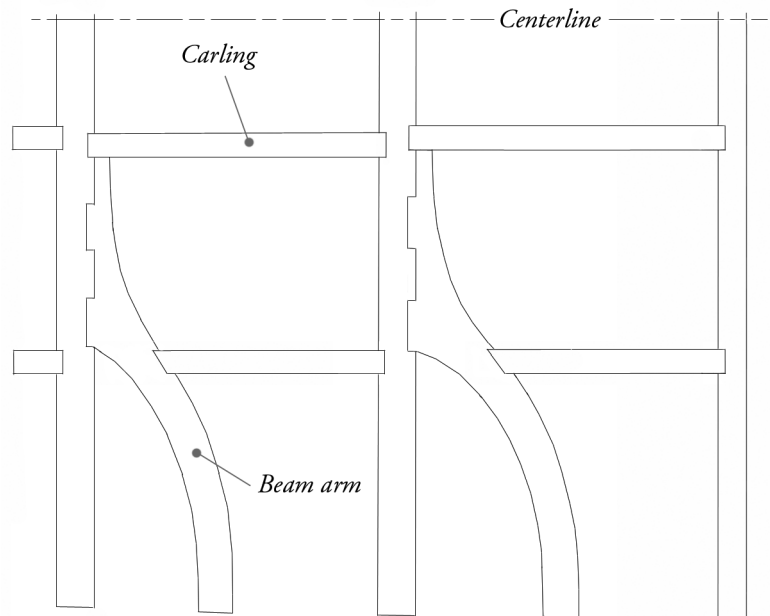

If you have not yet completed the ceiling planks at lower deck level, it is time to fit and secure these. Their dimensions can be taken from the cross-section drawings given previously. Leave a slot between the lowest plank and the lower deck beams for the waterway plank to be slipped in. I cut the stock for the waterway to use as a spacer when doing this.

One other easy task is to make the pillar in the hold under the deck beam at the dead flat (page 4 and opposite). This is 6" square at the base and 5" square at the upper end. Between, the corners are strongly beveled off at 45°. In actual practice, there are tenons on the ends of the pillars that fit mortises in the keelson and deck beam.

MAIN JEER AND TOPSAIL SHEET BITTS

Before laying the lower deck planking, there are other pieces to fabricate. There are four *bitt pins* that pass up from the lower deck beams to quarter deck level. The forward pair are the *main jeer bitt pins* and the aft pair are the *main topsail sheet bitt pins*. Both pairs have a dog-leg in them between the lower and upper decks. When installed, they must appear vertical as viewed from the side. Because they score on to the deck beams, the upper deck beams must be in the correct positions above the lower deck beams. One now begins to appreciate the interdependence of all the components in a ship!

Use my drawings only as a guide to making these pieces. Take the actual measurements between decks from your model, as they may vary slightly from the ideal. There are *sheaves* to be cut into all four pins. These are 7½" in diameter and 1¾" thick. Rather than fitting actual sheaves, I cut simulated ones as follows. Drill through the pins, fore and aft, at the top and bottom of the sheave slots. This can most accurately be done in a drill press. If you do not have one, mark out very carefully and drill the holes from both sides. Next, us-

ing a fine round 0 or 2-cut escapement file (a miniature sized Swiss file) gradually shape the 'sheave' by progressively filing into the holes from the midpoint between them. Alternatively, if you have access to hypodermic needles, cut one of a suitable diameter short and hone the cut end at 45°. This can be used as a miniature gouge to perform the same operation.

The decorative square sections can be carefully cut in with a well-honed chisel and define the bevels using a fine file or sanding stick. I would cut the scores for the beams and *bitt cross-pieces* with a chisel. Fit the beam scores to your own beams. Either cut the tenons on the lower ends of the pins, or drill and fit short dowels, as they will be hidden. Cut matching mortises as necessary.

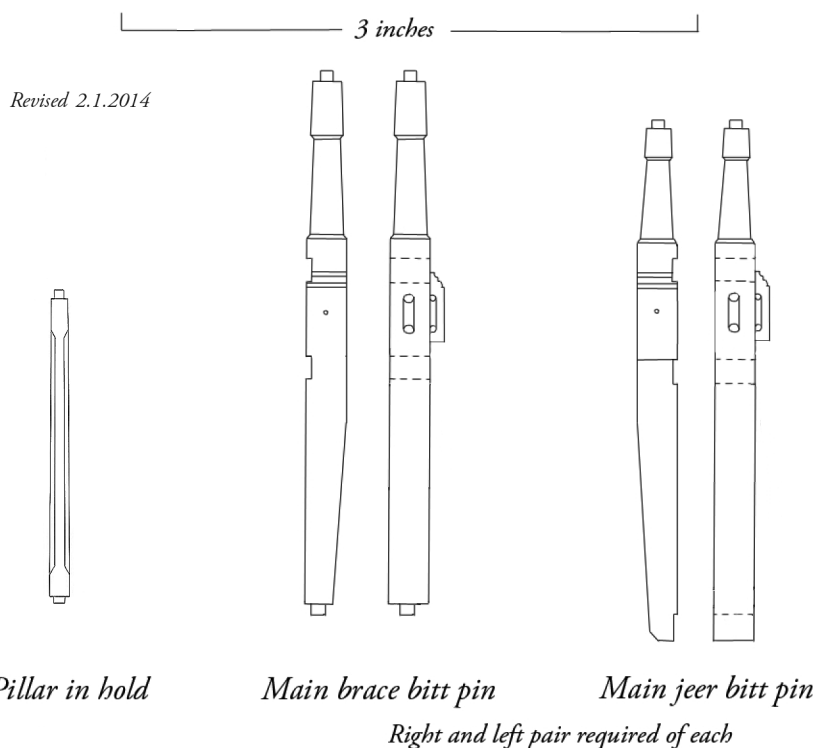

There are *cheek blocks*  $2\frac{3}{4}$ " thick fitted to the outer faces of the jeer pins. The sheave in each is  $7\frac{1}{2}$ " in diameter and  $1\frac{1}{8}$ " wide. Note the molded tops. I use a combination of chisels and escapement files to form the profile. Make sure that the bottom of the block is level with the top of the deck planking. The axis of the sheave should align with those through the bitt pin.

### THE LOWER DECK WATERWAY

The *waterway* defines the lower limit of planking on this level (illustration at right), and the upper deck clamp the upper limit. Between this are two strakes of what might be described as quickwork and one of spirketting. The clamp strake is already in place. Note the 2" air gap for ventilation.

The waterway is 3" thick and 12" wide. It angles down in section to 2" to meet the flat of the lower deck. If you have a mill, this is an easy way to make this piece. Otherwise sanding sticks, used carefully, can also achieve the same result. The spirketting strakes are 3" thick and each 10" wide. The quickwork fills the remaining gap and is 2" thick.

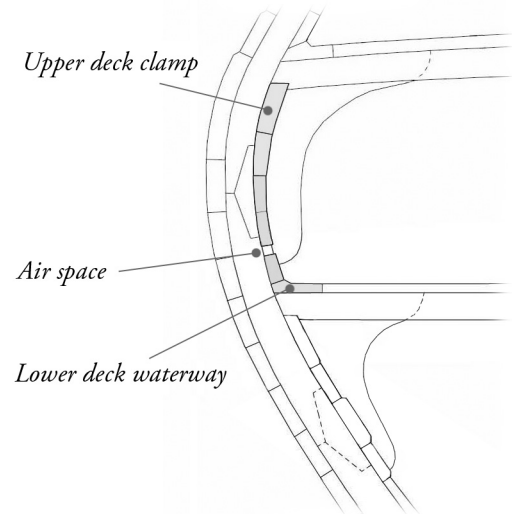

### COMPLETING THE LOWER DECK FRAMING

You already have made the lower deck beams. Now it is time to score them for the carlings. *Carlings* are 6" wide and  $4\frac{1}{2}$ " deep. There are two tiers of carlings, as seen on page 7. They score into the beams by  $1\frac{1}{4}$ ". Note that aft there are stub carlings that are cut short at the aft end of the cross section. The foremost beam is narrower than usual for the same reason.

Next are *hanging* and *lodging knees*. The contract calls for hanging knees at this level for only two beams before and aft of the main mast. Hanging knees are 6" thick and the side arm 4' 6" long, the beam arm 3' 0" long. There are seven bolts in each knee. Their general shape is given on the cross-section (above). Remember to give a slight bevel to the exposed edges of the knees; they should not have sharp corners.

Lodging knees are  $5\frac{1}{2}$ " thick, their athwartships arms 3' 6" long. There are six bolts per knee. Their positions and shapes are shown on page 7, along with the ledges. *Ledges* are  $3\frac{1}{2}$ " wide and 3" deep. These will take careful scoring and fitting.

All this work, carefully carried out, will take some time to complete. However, each piece is a small model in its own right and continues to create an overall picture of how these ships were constructed.

### LOWER DECK HATCHWAYS

The *lower deck coamings* for the hatchways are 4" high and 6" wide. Their head ledges are 5½" thick, as they are let down into the beams 1½". I would ignore making scores as they will be invisible and make the head ledges 4" high as well. They should fit the openings formed by the carlings and beams. There are rebates in the coamings for gratings 2" wide and deep. See the drawing below. (The aft hatch coaming will only be a partial one on the cross-section, as it is cut short aft.)

To radius the corners (see the sketch, below right), make an L-shaped guard 2" high. Place the coaming into the corner of the L, sitting on a flat surface. With a sharp chisel, bevel off the corner at 45° and file the corner to the quarter round shape. The guard will preserve the squared part of the corner for you. Often coamings were painted black.

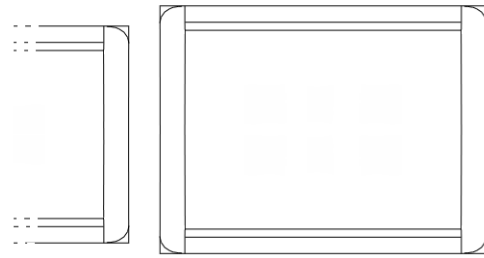

*Lower deck hatch coamings 1:48*

Gratings, made by any standard method, need to be made to fit the coamings. They should ideally have a mesh of 2½" square holes with 2½" battens, but no larger than 3". Adjust the batten spacing to fit each coaming. The main hatch grating was probably in two pieces, split athwartships, for ease of handling. Suitable commercial grating kits are now available.<sup>1</sup>

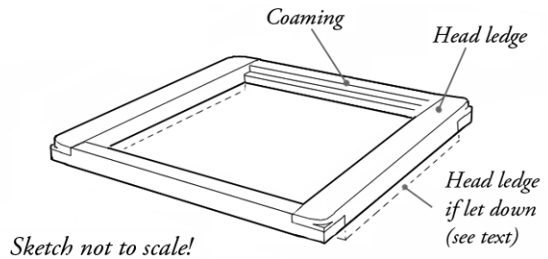

### LOWER DECK MAST PARTNERS

The *main mast partners* for the lower deck are simple compared to those of the upper deck. They are 4" thick, let down 1" on the beams. In other words, they sit 3" above the beams or 1" above the deck planking. They are 3' 6" wide and have a hole 19" in diameter for the main mast. They were probably made of two planks, as shown on the next page. If you are planning on showing a mast in your model, make up a dummy one now. The position of the hole is such that, when the mast sits in its step, it should be vertical in both fore and aft as well as athwartship planes.

<sup>1</sup> Syren Ship Model Company, at [www.syrenshipmodel.com](http://www.syrenshipmodel.com)

Trim the ends of the partners to fit against the head ledges forward and aft of them. Also, note that the side edges of the partners are beveled to meet the deck plank. Do not fit the partners permanently yet!

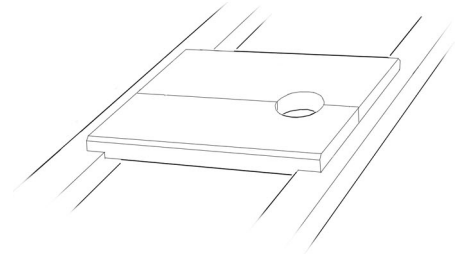

*Lower deck mast partners*

The other item that need to be taken care of are the holes in the partners for the chain pump return cases. The cases are not vertical, so you will need to position the upper deck beams and construct the upper deck mast partners in order to determine their locations. Study the cross-section opposite. In order to determine the positions of the holes of the various pumps through the lower deck, the upper deck partners need to be made now. So many things are interdependent!

The *lower deck planking* is 2" thick and about 10" wide, should you decide to lay it. Amidships the strakes run parallel. However, do not install this yet.

Temporarily install the upper deck beams and beam arms in the model before proceeding

#### UPPER DECK MAST PARTNERS

The *upper deck partners* have two substantial carlings 11" wide and deep and 2' 4" apart. They sit 6" above the top of the beams and are rabbeted 5" down for the cross-chocks. They sit in from the edges of their beams by 6", which is the width of the hatchway head ledges (see illustrations).

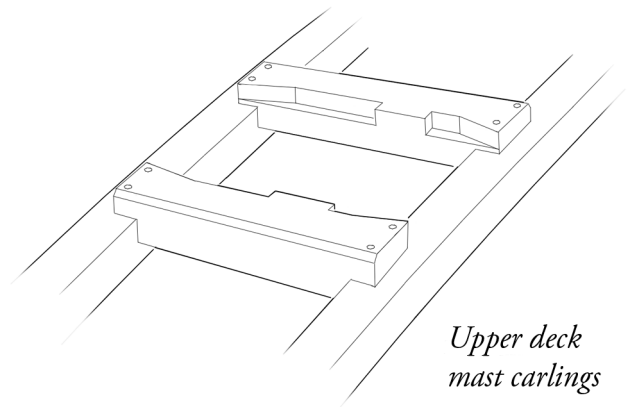

*Upper deck  
mast carlings*

The *cross-chocks* are 5" thick and form an octagon around the mast opening. If fitting a mast, you will need to open this octagon out to a circular

shape several inches larger in diameter than the mast. The space will eventually be filled with wedges. The plan view of the partners and cross-chocks is given on the following page. Do not install the carlings or partners permanently yet. (Yes, it's tempting, I know!)

Next mark the positions of the inner chain pump tubes or back cases. In the case of *Echo*, these are 11" square. Use the plan view (top of next page) to mark and cut these openings. The outer cases and elmtree pump tubes lie outside of the partners.

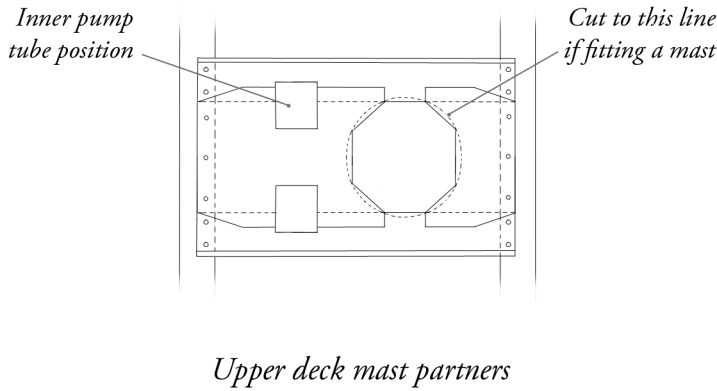

Cut a length of stock 11" square to act as a dummy case. With the upper deck partners in position and the lower deck partners removed, thread the back case through, so that its lower end sits against the side of the keelson (see below). You can now measure the offset of the tube from the centerline at the level of the lower deck and mark out the position of the square hole in the lower deck partners.

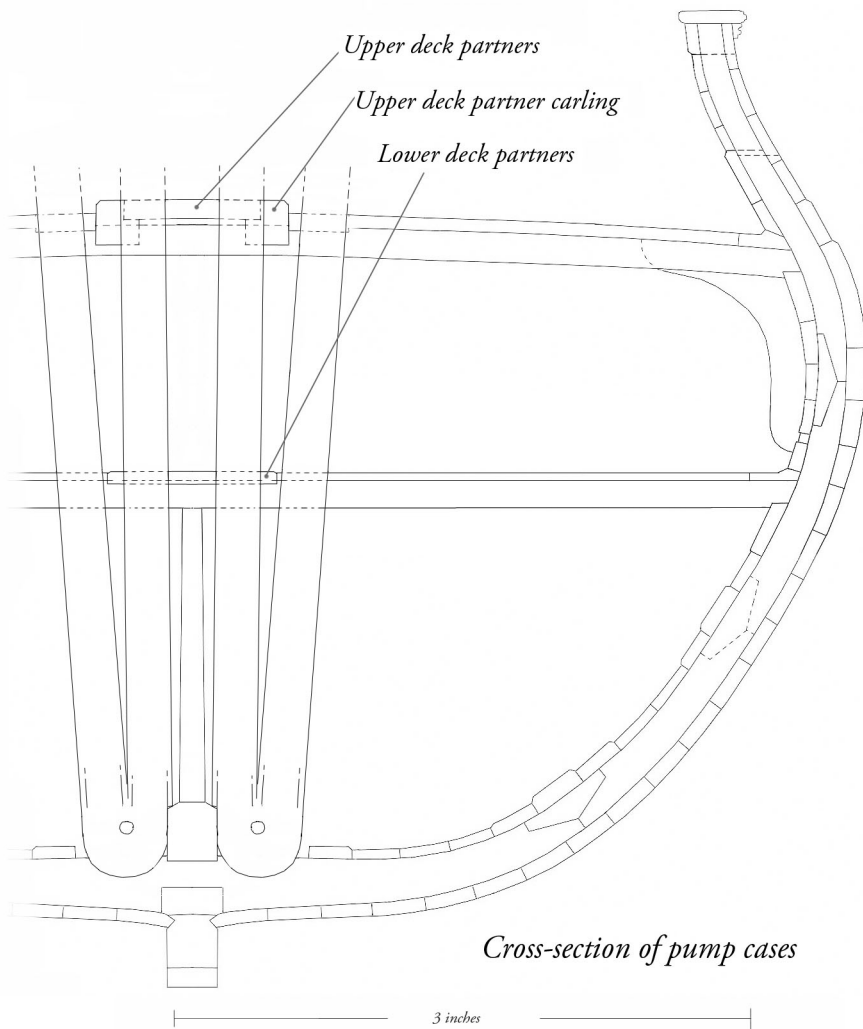

Cut the apertures in the lower deck partners on the slight angle and install them permanently. First check that the dummy case can slide through without binding. Also cut holes for the bitt pins that you have already made.

If you are planking the lower deck, the positions of the other pump tubes need to be ascertained. Proceed as follows: Using the pattern provided on the next page, mark it out on a piece of card whose edge sits along the outer edge of the carling. Cut the apertures out and tape the card in position on the upper deck next to the upper deck partners. Dummy tubes and cases may be slid through. The outer

chain pump case comes down to meet the back case at the limber channel as seen above. The elm tree pump tube also angles downward to sit in the limber channel (illustration overleaf).



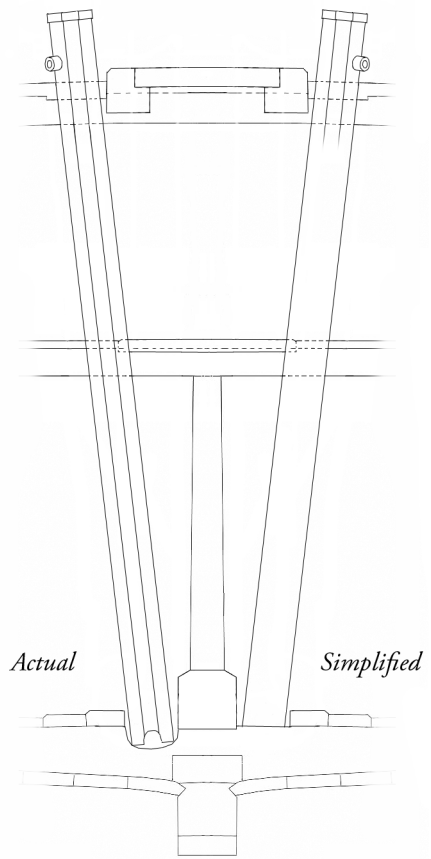
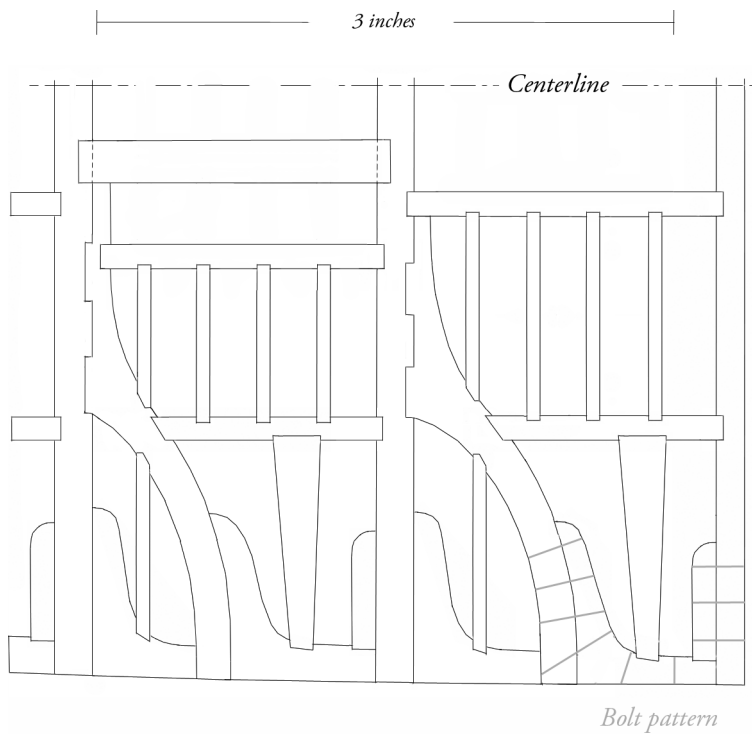

*Brake pumps, scale 1:48*

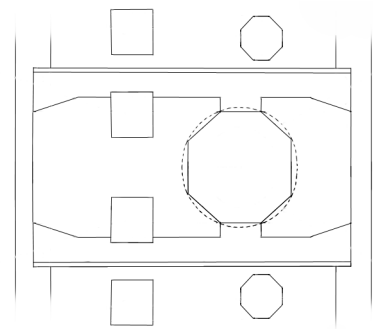

*Pattern for the pump tubes*

Make up a card at lower deck level that will be the template for cutting the holes through the decking there, once it has been laid. Use the pattern, below right, as a guide. The tubes and cases should just clear the lower deck ledges. You may now lay the lower deck planking if you choose to do so. *Note: eyebolts around the main mast should be added now: see page 34 for details.*

### COMPLETING THE UPPER DECK FRAMING

Next are the *upper deck lodging* and *hanging knees*. The hanging knees are sided  $6\frac{1}{2}$ ", vertical arms 5' 6" long and the thwartships arm 3' 4". They are fastened with seven 1" diameter bolts (see the illustration above). The lodging knees are sided 6" and their thwartship arms are 3' 9" long. There are three bolts into the beam and three, if possible, through the frames.

This work is very similar to that of the lower deck framing, so you have had plenty of practice! Next are the carlings at the hatches and outboard of the pumps. These are  $6\frac{1}{2}$ " wide and 5" deep. Finally, there are the ledges. These are  $3\frac{1}{8}$ " wide and 3" deep (you can simply make them 3" square) and placed as shown on the plan above. Note the two wider ledges on the outboard tier.



## UPPER DECK HATCHWAYS

The *upper deck hatch coamings* are higher than the lower deck ones, as there could be water washing over the weather deck. Again, their inner dimensions should be the same as the opening formed by the beams and carlings. The height of these is 12", and they bed directly on to the framing. They will sit 9" above the deck planking, which is 3" thick. The coamings are 6" wide at the base, but taper above the deck planking to 5" at the top. They have 2" rebates.

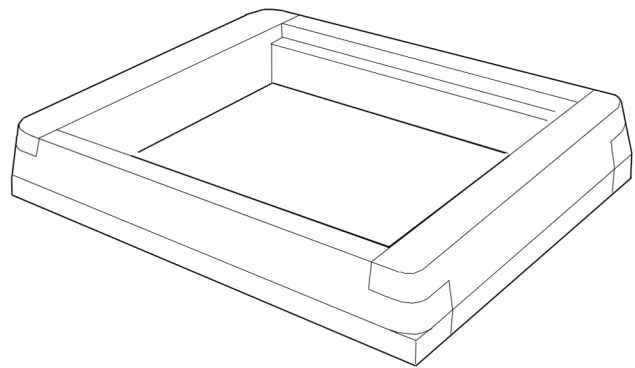
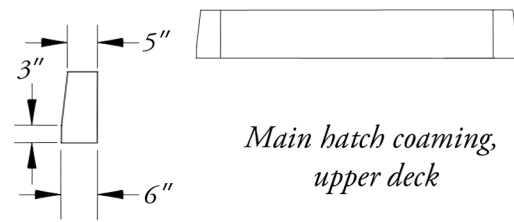

The easiest way to make the taper on the coamings is to make the pieces 6" wide all the way up, and assemble them. Mark out a line 3" up from the base all the way around and on the upper surface 1" in from the outer edge. Using a sanding block flat on the workbench, sand each side down at an angle until you reach the marked lines.

Cut the corners as for the lower deck coamings, except make the L-shaped guard 3" high this time. This is the thickness of the deck planking here. Coamings here were often painted black. These hatches will also require gratings, made to fit as you did for the lower deck. In this case, the gratings will have round-up.

## UPPER DECK WATERWAY

The *upper deck waterway* is 4" thick and reduces to 3" inboard. Its cross-section is similar to the waterway on the lower deck (see cross-section, page 15). You are now at the stage where the upper deck may be planked, if you wished to do so. The planking is 3" thick and no more than 10" wide. The exceptions are the binding strakes, should you wish to show them. They are the second and third strakes outside the hatch openings. These are 3¾" thick and score down on the beams by ¾". The cross-section on page 4 also shows these. Use the card pattern for marking and cutting the pump tube and case holes through the deck planking, if laid. Also allow spaces for the bitt pins, which may now be installed.

## UPPER DECK DETAILS: BRAKE PUMPS

It is time to turn attention to the various fittings associated with the ship's pumps. You already have the dummy cases. I will describe simplified brake and chain pumps. Should you wish to fit fully detailed pumps with their chains inside the cases, please refer to *The Fully Framed Model*, Volume II, Chapter 8.

The *brake pumps* are octagonal, so begin with your previously prepared dummy pump tubes. They should be slid into position and the upper ends marked 1' 6" above deck level. They can then be removed and cut to length. The illustration, page 16, right side, shows a simplified version. The upper end of each tube may now be bored out to a diameter of 6". A side discharge tube, shown, is 3" in diameter with a 2" bore. These tubes should point diagonally outwards and aft.

The handles, or brakes as they are more properly called, are constructed as illustrated. They are oriented outwards and forward.

The shape and form of the wooden fork varied, but that shown here is typical. In some ships an elaborate metal fork was in use at this time, but I suspect that this was more common on larger ships. There was a metal reinforcing band or strap around the head of the tube. I would make this 2" wide and of thin card stock painted black.

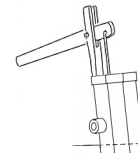

*Brake pump head,  
view from aft, scale 1:48*



*Detail of fork,  
not to scale*

The handle of the pump was about 3' 6" long, 1½" thick and 3" wide at the inner end. The spear or rod going down the tube was 1" in diameter. This may be made of blackened brass wire.

## CHAIN PUMPS

Next are the *chain pumps*. Look at the drawing on the following page. If you are making the more detailed version, you will need to hollow out the framing at the base of the pumps. Both the back (down) case and up (discharge) case are square in section. The back case is made of 1" board and the up case is a solid, bored out log. This refinement may be ignored for the simplified version and both cases built up. The top ends of the cases are 1' 6" above deck level.

The up case, in the detailed version, is bored out with a 6" diameter hole. Both cases are reinforced with a 2" band at the top. This detail is omitted from the drawing. There may have also been reinforcing bands around the back case every few feet along its length. The intake at the base of the pumps

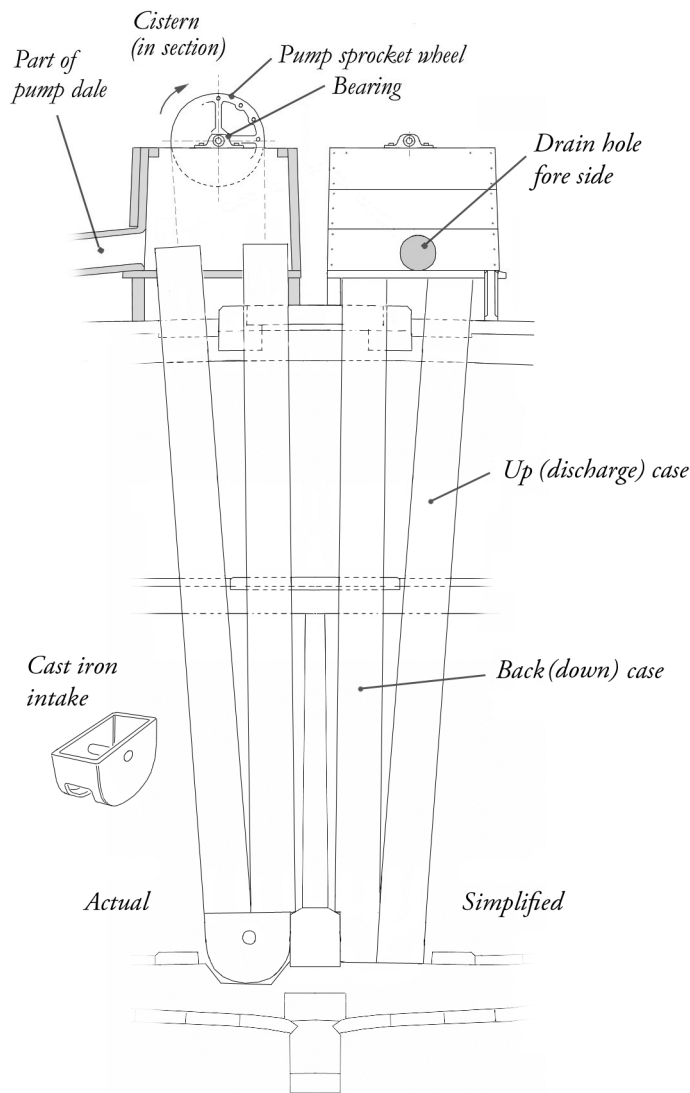

*Chain pump layout, scale 1:48*

was of cast iron, shaped as shown in the perspective drawing. If the well in your model is closed, there is no need to make the intakes.

### PUMP CISTERNS AND DALES

The *pump cisterns* are as shown at the left and on the following page. In the simplified model these can be made as solid blocks rather than built up. You will be in good company: some contemporary models such as *Princess Royal* of 1773 were built this way. Parts can be scaled from the drawings. On some ships there was a communicating pipe between the starboard and port cisterns at their lowest level. I assume this was so that the pumps could discharge along the opposite, leeward dale even when the ship was heavily heeled.

The drawings here and overleaf should be self-explanatory for constructing the cisterns. On top are semi-circular *hoods*, to prevent debris from falling into the pumps. Again, these may be shaped from solid wood if you are not fully detailing the pumps. There is a metal tongue for holding the hood open using a latch pin.

There is also a drain plug with a leather washer on the forward side of each cistern. The plug has a rope handle.

The last external features are the *pump dales*. These directed the water to the sides of the ship and out through the scuppers. By the time of *Echo*, these were no longer bored out logs, but made up from plank boards. Dales were stowed unless in use. However, if you wish to show these, details are found in *The Fully Framed Model*, Volume II, section 8.51. You may need to adjust the angle and length of the dale to suit your model.

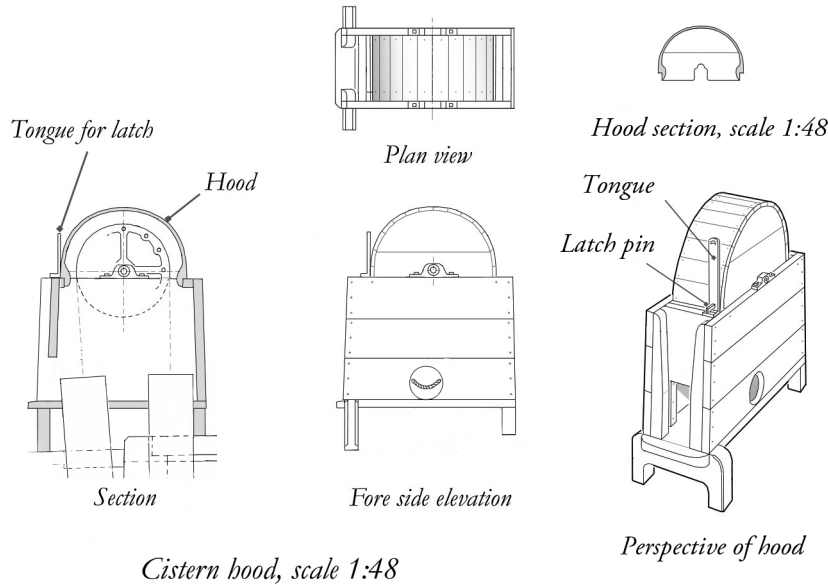

*Cistern hood, scale 1:48*

### CHAIN PUMP WINCHES

Next will be to determine where the *rhodings* or bearings for the pump cranks will attach. Begin by sliding a rod 1½" in diameter through the *rhodings* (bearings) on the sides of the cisterns. This is the axis from which you will determine the positions of the other bearings. There are rhodings on the bitt pins (circled, below) and through the end supports. If you

wish to fully detail the rhodings, they are illustrated in Volume II of *The Fully Framed Model*, page 95. Greg's model shows a different form of rhoding seen on a contemporary model.

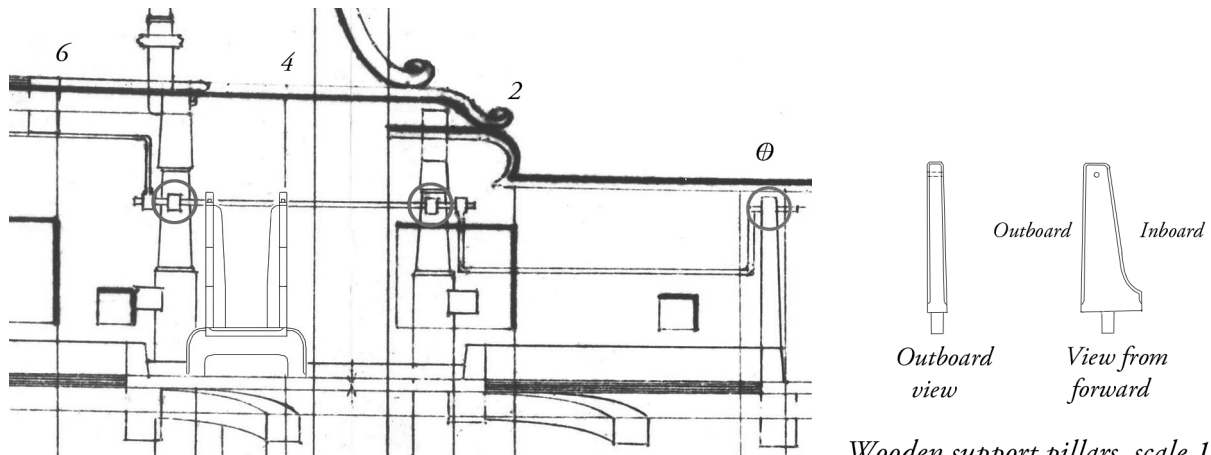

*Wooden support pillars, scale 1:48*

The *end supports* are of wood and tenoned into the main hatch fore head ledge. Measure the height and distance apart of these uprights from your test rod. The support pillars are detailed above. I suggest pegging rather than tenoning these supports. (Some models show metal supports: see page 22.)

The actual form of the supports is conjectural. However, the deck plan shows its footprint on the hatch coaming. This measures 1' 3" wide, but the support would undoubtedly be narrower at the head.

We will now deal with the pump axletree, winches and other metalwork. This will complete work on the upper deck. Read through the following before beginning to see what materials and supplies you will need to complete things successfully.

Before proceeding, make and install the crosspieces for both main jeer and main topsail sheet bitts. They are 6" deep and 7½" wide. The main jeer bitt crosspiece is 8' 3" long and the main topsail sheet bitt crosspiece 7' 6". Shape these as shown here. Each joint is secured with two bolts, diagonally placed.

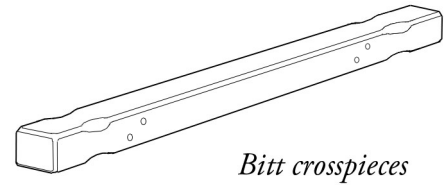

*Bitt crosspieces*

The first order of business will be the *axletree*. This is the section of the winding mechanism that passes through the cistern and, in the real thing, is attached to the sprocket wheel inside. (See the illustration below, left side.) This was a length of square-sectioned iron. If you have access to 1½" (1/32" actual) square section brass, this would be ideal. It is available through K&S Precision Metals, or at your local hobby shop. If it is unavailable, substitute round rod instead. You will need, in addition to the above brass, brass rod 3/64" diameter, and tube 1/32" in diameter.

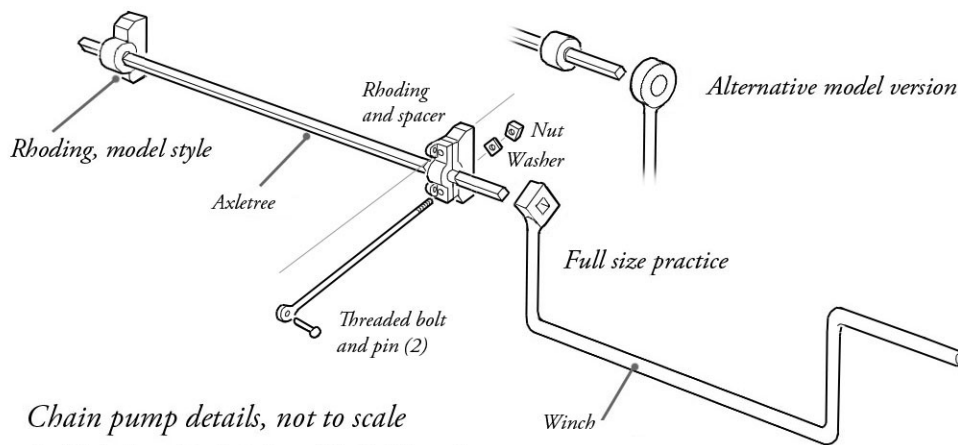

*Chain pump details, not to scale*

For full details, see *The Fully Framed Model, Volume II*

Measure the fore and aft distance between the bitt pins and check this against the drawing. Confirm that it is the same on your model. If not, you will need to compensate on the measurements that follow.

Cut two pieces of square section brass to length, which should be 7' 0". These will be the axletrees. They run on bearings called rhodings. There are two on each side attached to the bitt pins on wooden spacers. If you have not already constructed these, now is the time to do so. They may either be simple



3" lengths cut from 3/32" tubing, or constructed in detail, as shown in *The Fully Framed Model, Volume II*, page 95. (Also study the illustration above.) Another variety of rhoding is seen (left). It has a wooden spacer behind it, but a simpler one-part bearing and a retaining pin. Note that there is a shoulder at the end of the axletree to prevent the winch from slipping aft along it. The winch is retained on its axletree by a nut and bolt. This model is beautifully detailed.



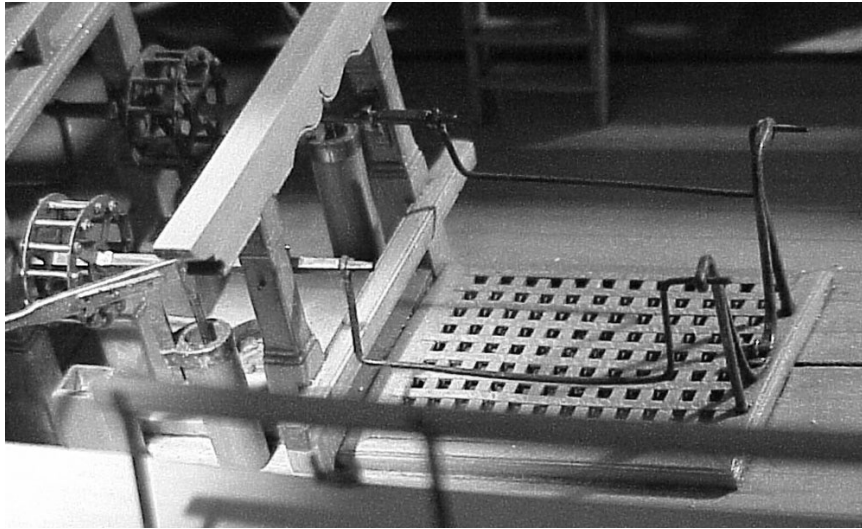

A sixth rate model, The Rogers' Collection, USNA Museum, photograph courtesy Grant Walker.

Chain pumps on a contemporary model are seen above. The cistern hoods are omitted, revealing the pump wheels, but the chains are absent. The winch end supports are of metal in this model.

Blacken all these parts. This may be done chemically using a brass blackening solution, available either through model suppliers such as Micro Mark, or jewelry supply houses. Dilute the solution provided at about 8:1 with water. It will not blacken effectively at full strength. Make sure the parts to be blackened are thoroughly clean. A few minutes in the solution will do. After blackening parts, wash them in water and buff them with a soft rag or paper towel.

Slide the square section rods through the cistern rhodings. If your work was accurate, these should slide past the bitt pins with just a little clearance. Thread the rhoding tube sections on to the axletrees and shape the wood spacers to fit. With a dot of epoxy glue, attach the rhodings to the wooden spacers. Finally glue the spacers to the sides of the bitt pins. Do not glue the rhodings to the axletree!

### METALWORK AND SILVER SOLDERING NOTES

Next are the winches. These are the cranked sections that are the handles for turning the pumps. The forward section may be bent up with three right-angled turns. In order to make this task easier, the  $\frac{3}{64}$ " brass rod will need to be annealed. Annealing is a softening process using a heat source such as a micro-torch run on butane. The metal needs to be heated to cherry red and allowed to cool. You can do this on a heat-resistant tile or mat. I have a set of 'third hands' with such a mat that is very useful for both this purpose and for silver soldering. (photograph opposite page).

**SAFETY:** Always wear eye protection and make sure that there are no flammable materials near where you are working with open flame. Be aware that the pieces you are working on can get very hot. They take time to cool down. Also be aware that the tip of your micro torch remains hot after switching it off. Pickle is caustic and should be handled with rubber gloves. Stainless steel or copper tongs should be used to retrieve items from the pickle bath.

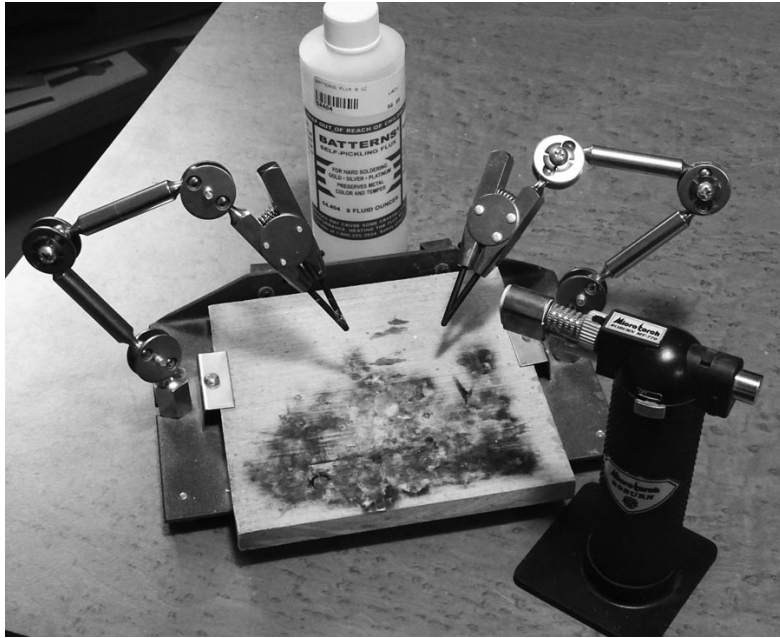

Once the rod has cooled, you may bend it. The metal will now bend easily. A pair of parallel pliers is ideal (jewelers' suppliers), and will be found useful for a variety of situations when working with rod or sheet metal. Bend up a piece of rod for each forward winch, leaving the aft end overlength for the moment. Cut four more 3" lengths of  $\frac{3}{32}$ " brass tube. These will need to have a  $\frac{3}{64}$ " diameter holes drilled in one side. Proceed as follows:

Ideally a small drill press and vise are needed, but the operation may be carried out without these. Hold the piece of tube firmly in the vise and file a small flat on the upper surface (illustration below). Chuck a  $\frac{3}{64}$ " diameter bit and align it with the flat spot. The flat will prevent the drill tip from wandering off the surface of the tube. (You may also carefully center-punch a mark on the flat.) Align the drill tip and tube. Setting the drill in motion, lower the quill slowly and steadily into the work. After drilling, file the inside of the hole to remove any swarf. Repeat for the other three pieces.

Next, solder the tube to the rod. You may, of course soft-solder or epoxy the pieces together, but silver soldering is the best method for jointing small parts. For this you will need to acquire some silver solder (either in sheet form or, more conveniently, in paste), liquid flux and pickle. For pickle, ordinary white vinegar may be substituted. However, it is much slower-acting.

Silver solder comes in different grades. These are designated, *hard*, *medium*, *easy* and *extra easy* in descending order of melting point. For simple assemblies such as this, only one grade will be required. I would use 'hard'. (It is not harder to use than other grades, though!) The reason for using the highest

melting point solder is that, if later on, you wish to make more complex assemblies, the first joint is made with 'hard', then the next with 'medium', and so on. This way the first joint will not fall apart while making the second, etc.

If you have never silver soldered before, there are several key points to the process. First is cleanliness. The surfaces to be joined must not only fit well – silver solder will not fill gaps! – but must also be free of dirt or grease. This may be assured either by mechanical abrasion or a solvent such as isopropanol. Second is the covering of the area to be joined by flux. This, brushed on, will prevent oxidation that will inhibit the joint from forming. Flux is cheap, so be generous! Third, proximity of the silver solder to the joint. If using sheet solder, a tiny speck cut off it is all that will be required. Each paillon (the speck of solder) should be about  $\frac{1}{64}$ " square. Convey this on a brush tip moistened with flux to the joint and it should stick by surface tension.

Begin by heating the joint area gently. The flux will bubble and turn white. If you heat too rapidly, the silver solder will be displaced or jump off entirely. Once warmed, bring the torch close to the work so that the flame tip heats both pieces to be joined equally. Watch the solder carefully until it flashes bright and runs into the joint. Immediately remove the flame. Allow the workpiece to either cool, or pick up with tweezers immediately and drop it into the pickle. Leave it there until the flux remnants are cleaned off. There is a learning curve to this process. You will likely have several failures to begin with, but persevere. After a while your success rate will approach 100%. Unlike soft soldering, the joint will be as strong as the metal.

Once the piece has been pickled, wash it in water, file the inside of the tube smooth and buff it up. Now it will be ready for the blackening process.

### COMPLETING THE WINCHES

Back to the item you are fabricating. The tube segment needs to be soldered to the winch in such a way that the winch, threaded onto the axletree and through the forward support, aligns nicely. (For purists, the tubular ring was actually square, like a box wrench, that slid on to the axletree.) Mark the aft end of the winch at the point where the tube should sit and cut off most of the excess rod. After ensuring that all the metal surfaces are clean - do not touch the area with your fingers; even traces of skin oils will cause the joint to fail – thread the tube on the rod end and solder as described above.



The aft winch is cut short at the end of the cross-section, but otherwise is fabricated in the same way. Once all the winch elements are complete and blackened, they may be attached to the axletree. Begin by sliding the axletree slightly aft. Push the fore end of the fore winch into the hole in the fore support, then slide the axletree forward to engage the aft end of the winch. A small spot of epoxy will secure the pieces together. The aft winch parts may now be constructed and attached as well. Cut the aft winch to a length that is flush with the aft end of the cross-section. This completes the pump details.

OUTER HULL PLANKING: THE MAIN WALE

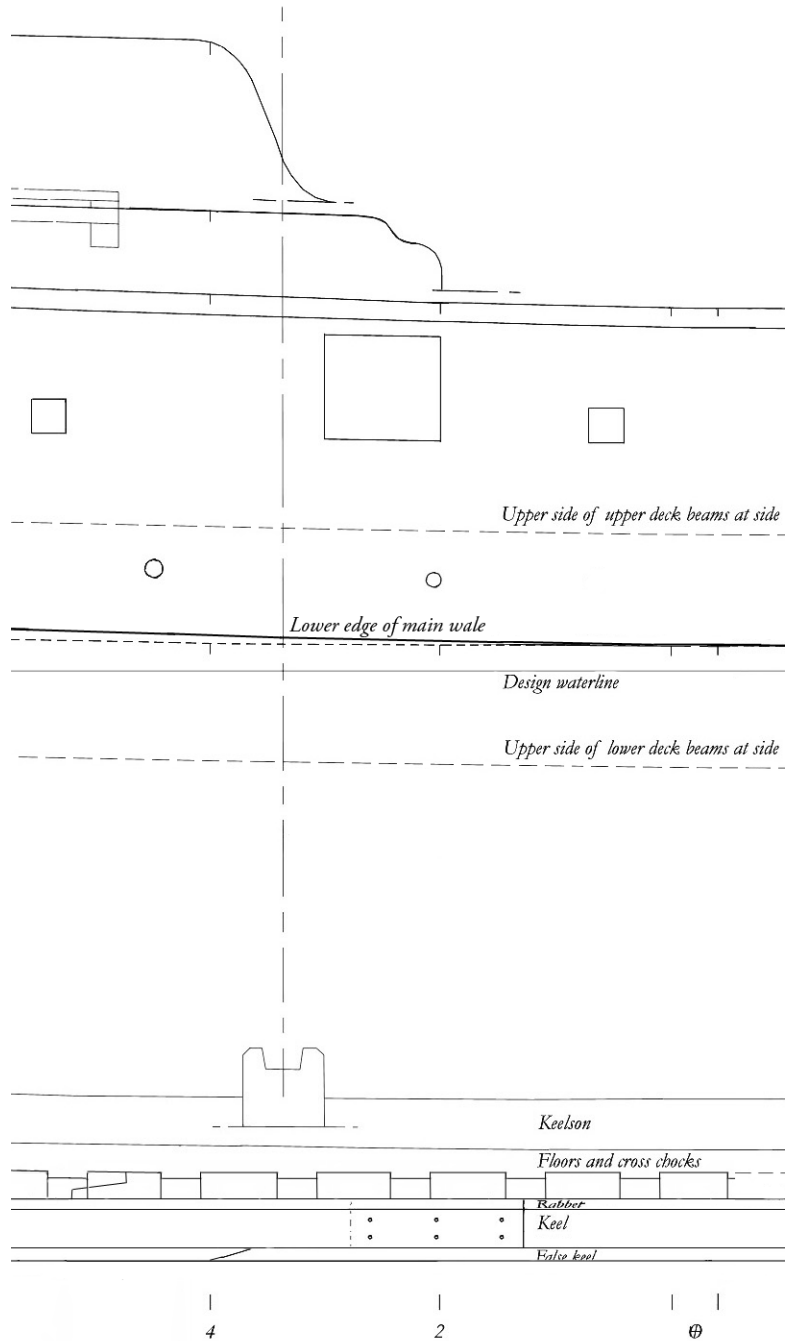

It is now time to turn attention to the outside of the model. You may wish to leave this unplanked on one side to expose the framing. As the hull does not vary much in shape over the section, planks here may be parallel.

The first task is to define the main wale. Once again, take all the measurements from your building board. In the case of *Echo*, only the lower edge of the wale is shown on the sheer plan (at left). Mark this line on your framing. The area below this line defines the bottom planking of the hull.

The main wale is 2' 6" wide and consists of three strakes. All are 4½" thick. The two lower strakes are worked anchor stock, 'hook and butt', and the uppermost is parallel and 10" wide.

Mark the upper limit of the wale 2' 6" above the line already marked. This defines the belt of planking. If you have not already done so, fit the blocks that support the scuppers. (See also the original framing plan that was supplied with the kit.) These blocks need to be carefully drilled for the scuppers. Proceed as follows:

The scupper pipes angle downward from the waterway internally to emerge externally through the main wale. If you try to drill these in one pass, you will probably damage the hull and most certainly come through where you do not intend to! First carefully mark the upper deck waterway with the positions of the two scuppers that are located in this section of the ship. If you are not planking the outside of the hull, mark the outer surfaces of the supporting blocks with the centers of the holes. If planking, delay any drilling until the wale is installed. Now take a drill bit no more than  $\frac{1}{32}$ " in diameter and begin to drill a pilot hole, eyeballing the angle through the side. Drill from *both* sides so that the holes meet in the middle. (I use a pin chuck for this exercise, as I can control things much more easily than with a power drill.) If the alignment is not perfect, this is not an issue. Gradually open out the holes, again working from both sides. This will correct any misalignment. Finally open out the regular scupper to 4" diameter and the pumpdale scupper to 5" in diameter.

If you are planking, the same procedure is used after the main wale is on. However, before marking and drilling, I would tape over the wale to protect the finish from scratches or other marks.

However, back to the wale. I would install the upper 10" strake first. The planking diagram is provided here. Note that the pumpdale scupper coincides with a butt between two planks (below).

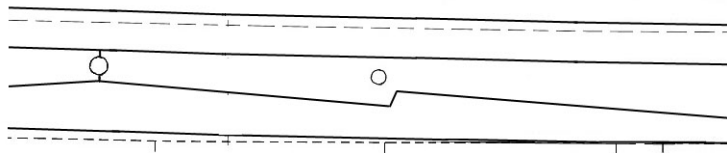

*Suggested main wale layout, scale 1:48*

The two lower strakes show part of the anchor stock 'hook and butt' planks. As the side of the ship is virtually vertical here, you can take the pattern directly off this illustration. If you are leaving the wale unpainted or dyed, consider black tissue or paint on the seams to emphasize them. Before going further, remember to chamfer off the upper and lower edges of the wale by 1" to meet the planking above and below it.

When you have completed this, now is a good time to paint or dye the wale. This saves tedious masking, or worse; an accidental spill on the other outer planking.

### LOWER HULL PLANKING

The area between the keel rabbet and main wale is covered with the bottom planking. For the most part, it is 3" thick, with the following exception. The first plank below the main wale is 3½" thick and the second strake below this tapers across its width to 3" thickness at the lower edge. I would make the bottom planking no more than 10" wide. As the cross-section is so short, I would not concern myself with any plank butts. However if you wish to show these, there should be three clear strakes vertically between any butt and no less than 6' 0" between butts on any adjacent strake. This rule includes the plank of the wale: there need to be another two clear strakes under the butt at the pumpdale scupper before another butt is worked. Butts usually fall in the center of a frame futtock or toptimber. The butt of the wale is an exception: it falls over the scupper support block.

It is time to take the model off its building board in order to plank the underwater hull. To ensure a good run for this planking, take a paper tick strip and measure off the girth from the rabbet of the keel to the lower edge of the main wale. Check whether this is the same at the dead flat as at station 6. If not, you will need to subdivide both strips into equal parts no more than 10" apart. Transfer these marks to the frames to give you the run of your planking. While attaching the strakes, make sure that you do not get 'creep' away from your mark-out.

Add black tissue or pencil the plank edges to emphasize them if not applying copper plating. For plating, consult a text or go on-line. However, you may prefer to leave your workmanship exposed. Also, you will need to slightly bevel the long edges to avoid gaps, particularly at the turn of the bilge. If you care to, treenail the planks to the frames with two per frame, drilled and driven in a diagonal pattern. Replace your model on the building board and tighten it down.

### TOPSIDE PLANKING

It is now time to plank the upper hull. The first strake above the wale is called the black strake. This was not invariably black on contemporary models, so it is a matter of choice. This strake is 3½" thick and 10" wide. It tapers in thickness to 2". The planking above this is also 2" thick but, before laying it, I recommend installing the sheer strake. This is 10½" wide by 3" thick and runs along the top of the toptimbers. The remaining space is filled with four strakes, each 8½" to 9" wide. Again, measure this space on your own model to confirm the actual plank widths. The planking scheme is shown overleaf.

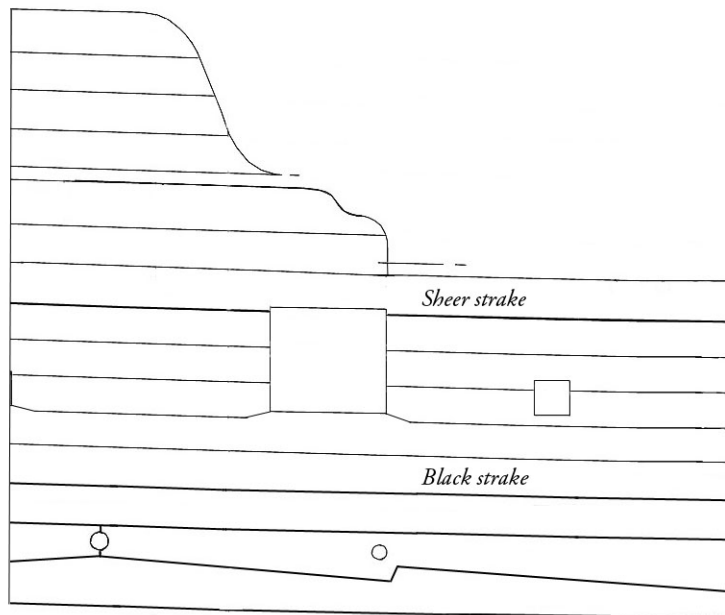

*Topside planking scheme, scale 1:48*

There are some interesting features seen in 'real world' planking. If the edge of a port comes more than halfway across a plank, instead of the plank being cut into, the adjacent plank is widened to meet the port edge. You can see this feature in the first strake above the black strake (above). Of course, you may simplify matters and ignore this if you wish.

There are two further 2" thick strakes above the sheer strake that form the *drift* or rise in the side for the quarter deck, but I would leave these off until the quarter deck clamps and beams are in place.

### THE QUARTER DECK CLAMP

The height of this is measured from the sheer plan in the same way as you did for the other decks. There is a slight complication in that, due to the tumblehome of the ship's side, a measurement straight up from the building board is not possible at the fore end of the quarter deck. So, measure up at the aft end. The vertical rule can be moved across the 'cut' end of the model. As the quarter deck runs parallel to the upper deck, a measurement may then be taken from the upper deck beams or top of the planking, if you have planked that deck. In the case of the quarter deck, the beams are not let down on the clamps.

The quarter deck clamp is laid in two strakes (see above). The upper strake is 3" thick. The lower strake tapers across its width from 3" to 2½" at its lower edge. The lower edge aligns with the upper edge of

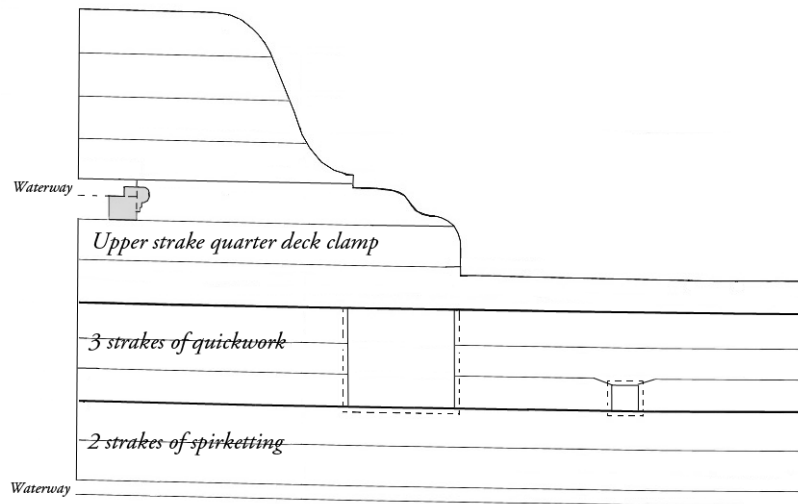

*Inner bulwark planking, scale 1:48*

the port openings. This lower strake extends forward as the 'string in the waist'. Both strakes are nominally 11½" wide. Once again, measure this on your own model. If not using paint, consider emphasizing the joints as you did for the underwater hull planking. (Also, see paint notes on page 45.)

At this time period, the inner bulwark planking, port sills and stops were painted dull red.

### PORT STOPS

The port stops now need to be added before continuing to plank the inner bulwarks. The stops are 1" thick and span the width of the framing. Cut and fit the lower stop first, then add the side stops (illustration below right). There is no stop across the top of the gun port. Stops are also required on all four sides of the sweep port. (See dashed and solid lines, illustration above.) This is fiddly work.

One strategy for making the stops is to shape the outer edge contour and then cut to length or height. Leave the inner edge wide and glue the piece in. Once all the stops are completed, sand the inner edges down using a sanding stick, until they are flush with the inside of the framing. This will give a level surface for the inner bulwark planking.

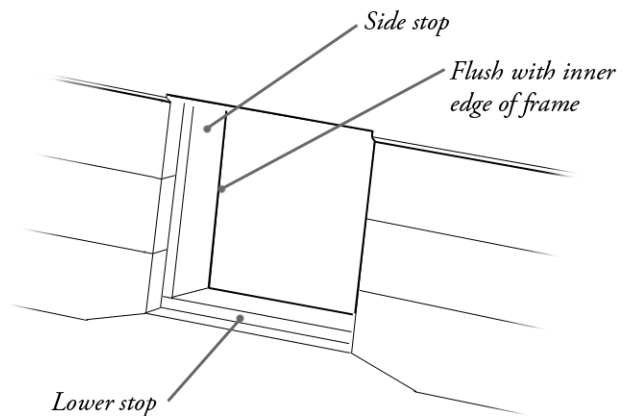

*Port stops*

## UPPER DECK SPIRKETTING AND QUICKWORK

The upper deck spirketting is in two strakes (see illustration, previous page). Often this is cut either anchor stock or top and butt fashion. However, the contract for *Echo* does not specify this style of construction, merely that it be in two strakes of 3" thickness. The upper edge should be softened to a quarter round section.

The quickwork is in three strakes of 2" thick plank. In both cases, you will need to measure from your model to determine the width of these strakes. The contract specifies that the ends of the planks at the ports be also softened to a quarter round section to match that of the spirketting.

## UPPER DECK BULWARK DETAILS

There are a number of inboard details that should be added at this point. The first of these are the various ring and eyebolts at the ports for the guns. I usually make mine of brass wire that has been annealed. The eye of the bolt is formed around a pair of fine needle-nosed pliers and the shank bent back at a suitable angle. Rings are formed by winding annealed wire around the shank of a drill bit of the appropriate size and either cutting the rings with a fine razor saw or filing through with a watchmaker's screw slotting file. The rings are silver soldered closed, then the bolt eyes are closed around them. For security I epoxy the stems into the holes.

A small refinement: usually eyebolts in models are seen protruding too far out of their holes. In the actual ship these were sunk into the wood, as shown. To provide the depression in the wood, I use a flat-bladed jeweler's screwdriver of suitable size. This is pressed in at a 45° angle after the hole is drilled.

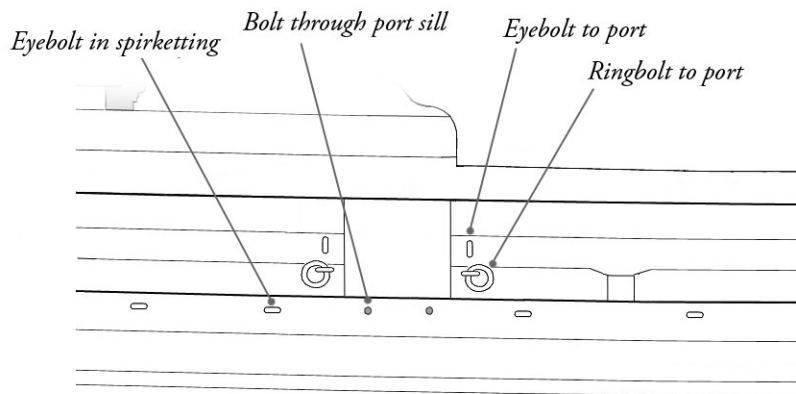
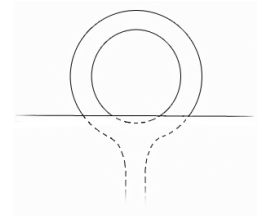

*Inner bulwark metalwork, scale 1:48*

The sizes of the metalwork are as follows: all metalwork  $\frac{7}{8}$ " in diameter. The rings are 4" inside diameter, the bolts to fit. I blacken items chemically as for the pump parts as described on page 22.

There is a ringbolt on each side of the port that attaches through the lowest strake of quickwork. Note that, in the real ship, the stem of the bolt passes right through the bulwark and outer planking to be held in place by a forelock. This is a piece of sheet metal that is bent, once in place, into an S-shape to retain it in its slot. You may wish to show this feature, rarely seen on models. I have successfully imitated this by two small pieces of black paper glued on either side of the protruding stem of the bolt. Of course, this is a stub piece of wire driven from the outside of the hull.

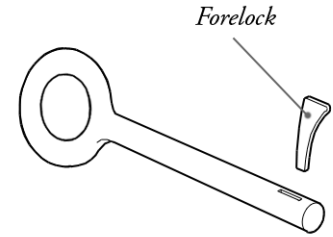

*Forelocked bolt*

An eyebolt is similarly driven through the middle strake of quickwork as shown (below left). There are also four eyebolts driven through the upper strake of spirketting as indicated.

### QUARTER DECK FRAMING

With the quarter deck clamps in place, the *quarter deck breast beam* may be prepared. This has a rebate for the deck plank ends to house into, as well as a decorative and practical water channel along its forward edge. This beam is more easily built up than shaped from solid.



*Quarter deck beam pattern, scale 1:48*

Cut a beam to the pattern above, ensuring it will be long enough for your model. It is 6" wide and 5" deep. There are two pieces to be added, as shown in the diagram (left). The basic beam is shown in

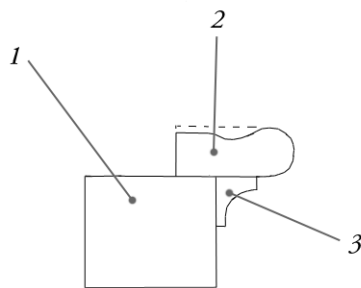

*Breast beam section, no scale*

cross-section (1). First glue a strip 3" thick and 6" wide along the top surface, overlapping the edge of the beam by 2" (2). The fore edge of this should now be rounded to a bullnose section. Next, run a shallow channel along the strip 2" to 3" aft of the front edge. One could either use a mill for this, a shaped scraper or sanding stick. End the channel about a foot from the ends of the beam. It will be matched in to the waterway later. Level the surface aft of this to 2½" thickness as shown (left). Finally add a strip of cove molding 2" square along the underside of 2 (3).

The molding may be produced on a mill, using a suitable small round cutter. Otherwise, using a scraper cut to the appropriate profile will produce the same result. Some practice with this simple section will prepare you for scratch-molding the ornamental rails outboard.

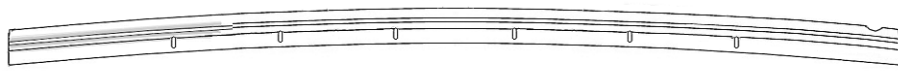

*Bolt positions in breast beam, scale 1:48*

There are also six eyebolts driven into the fore edge of the breast beam. These are similar to the others that you have already made. Their positions are shown above. The beam may now be cut to length and located on its clamps. However, do not attach it permanently yet.

#### FINISHING THE MAIN JEER BITTS: THE GALLOWS CROSSPIECE

To complete the jeer bitts, the gallows crosspiece needs to be made and installed. Carefully drill into the tops of the bitt pins and cut small lengths of wood to act as tenons. The crosspiece is 7" wide and 11" deep. Its length is such that the ends are 2' 0" outside the bitt pins. The crosspiece should be 10' 0" long. The lower edge was often cut in a decorative shape, as illustrated here. Carefully measure the distance between the tenons on the bitt pins and drill holes in the underside of the crosspiece. Fix the crosspiece to the bits.

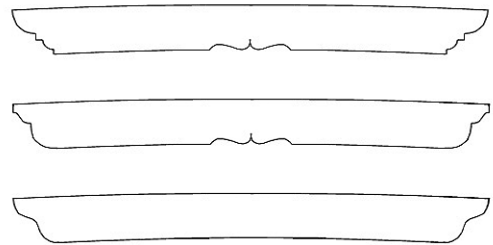

*Shapes of gallows crosspieces, scale 1:48*

#### FITTING THE QUARTER DECK BREAST BEAM AND WATERWAYS

The main topsail sheet bitt pins tenon into the underside of the breast beam. This is seen on page 20 in the partial profile. Hopefully the upper ends of the bitt pins are at the correct height to meet the underside of the beam when the beam ends are firmly seated on the clamps. If not, either file the tops down carefully or add a shim if necessary. Again, drill and add pins as you did for the gallows crosspiece. Leave the beam temporarily in place.

The quarter deck waterway is 4" thick and 10" wide. As the cross-section ends just aft of the breast beam, very short pieces will be needed. It is shaped similarly to the other waterways. The inboard part is 2½"

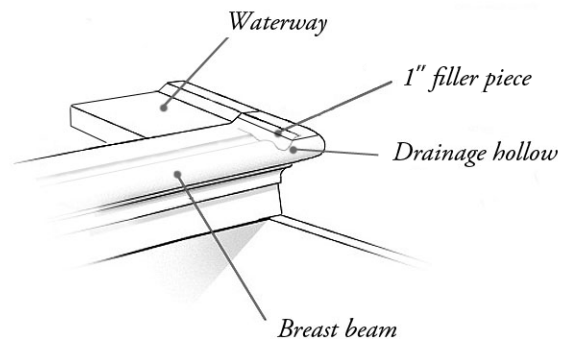

*Waterway detail*



thick. A 5" high filler piece, 3" thick, will need to be placed on the clamp under the waterway, to position the waterway at the level of the beam top. Cut the waterway to abut to the breast beam and secure both filler and waterway in place.

There is now some shaping to carry out between the waterway and the beam end on each side. This is hard to describe, so refer to the illustration at the foot of the previous page. The shallow gutter along the breast beam is extended to almost the outer end of the beam, where it meets the waterway. A drainage hollow is cut or filed across the lip of the breast beam. Make sure that the gutter will be clear of the berthing up - the 2½" thick side planking above the waterway. A filler 1" thick is needed to even the top surface of the beam end with the waterway at the side.

Lastly, the cove molding on the breast beam and the bullnose needs to be trimmed back 3" so that a piece of plank above the clamp can abut the fore side of the beam (illustration at right and see page 29, top).

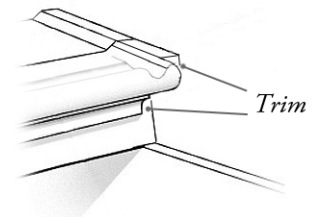

*Beam end detail*

### THE QUARTER DECK BREASTWORK

This consists of five stanchions and two rails. The stanchions may be turned from 6" square stock if you have a suitable lathe, or made square in section. Note that, apart from the central stanchion, the top and bottom of each is angled to match the quarter deck round up.

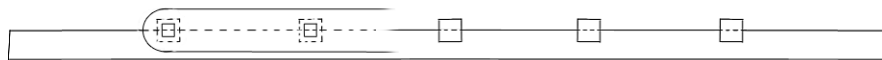

*Plan view*

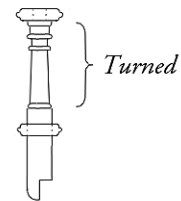
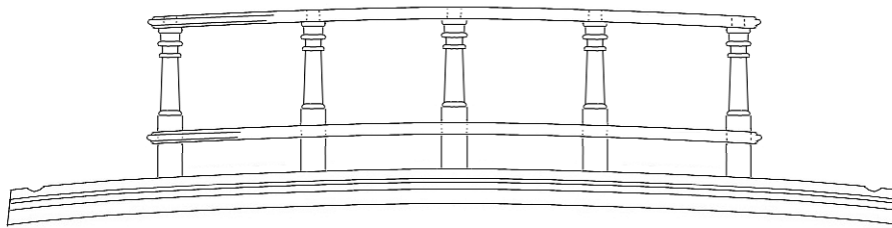

*Quarter deck breastwork, scale 1:48*

If you have a duplicating device for the lathe, it is easy to replicate the five stanchions to the same pattern. If not, careful mark-out will assist in making all the pillars identical. Note that the lower ends of the stanchions are half-jointed and bolted to the aft side of the breast beam. The upper ends of the stanchions are tenoned through the top rail. Purists may wish to add a fore-and-aft sheave through each stanchion just under the lower rail.

The rails are 11" wide and 3" thick. Their ends are shaped to a half-round and the edges beaded in an *astragal molding* (right). This beading is best done by careful scratch-molding. The lower rail is pierced so that the stanchions will just pass through. Careful marking out, drilling, then followed by work with a square file is a good strategy. To ensure symmetry, drill both upper and lower rails together with a 1/16" bit. Use a piece of scrap 6" square stock to use as 'a go/no go' gauge while opening up the holes in the lower rail. The mortises in the upper rail are 3" square. Use the same technique for consistent mortises.



Place each stanchion over the illustration to cut the upper and lower shoulders to the correct angle. Leave the top tenon a little over-length for the moment. Thread the stanchions on the lower rail, then glue and pin the stanchions to the aft side of the breast beam, ensuring that they are vertical. Glue the lower rail in place. I use spacers under the rail to ensure that it runs parallel to the curve of the beam. Now glue the upper rail over the tenons. Finally shave or sand the tenon heads flush to the top of the rail.

The breastwork assembly may now be permanently installed on the model. Make sure that the stanchions are vertical when viewed from the side. If you wish to add stub lengths of quarterdeck planking aft of the breast beam, you may add this in the usual way. The planks are 2½" thick.

### THE BERTHING UP

This is the planking that covers the bulwarks of the quarter deck. Four planks, 2½" thick, will cover the timberheads inboard from the waterway up to the level of the roughtree rail (see page 29). Four planks, 2" thick, cover the frames outboard. Leave a 2½" gap for the planksheer (page 42) above the drift planking. This completes work to the quarterdeck.

### IRONWORK AT THE MAST PARTNERS

There are four eyebolts driven into the partners each side of the main mast. There are two possible arrangements, illustrated at right. The eyebolts are either arranged radially (below) or in two lines fore and aft (top). You may choose either arrangement; both styles are seen on contemporary models. These eyebolts are similar to the ones that you have already made (page 30). Remember to 'sink' them slightly into the partners. This completes work at the upper deck level except for the fixed gangway. Now it is time to focus on the external hull.

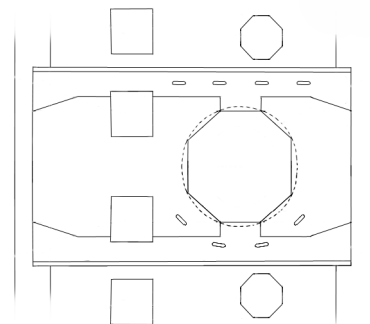

*Eyebolts around main mast*

## THE EXTERNAL HULL FITTINGS

There are many interesting items to construct on the outside of the hull.

## SCUPPER LININGS

The two scuppers in this cross-section are already drilled and opened out. Now we shall imitate the lead linings at the ends of the tubes. There are many possible ways of doing this. I have found that the easiest way is by using acrylic paint. Mix a medium shade of grey from black and white paint. Using a small good-quality brush that comes to a fine point, paint the inside of the tube. Then carefully paint a ring around the opening, as indicated above. Build up layers of paint to give a thickness to the flange.

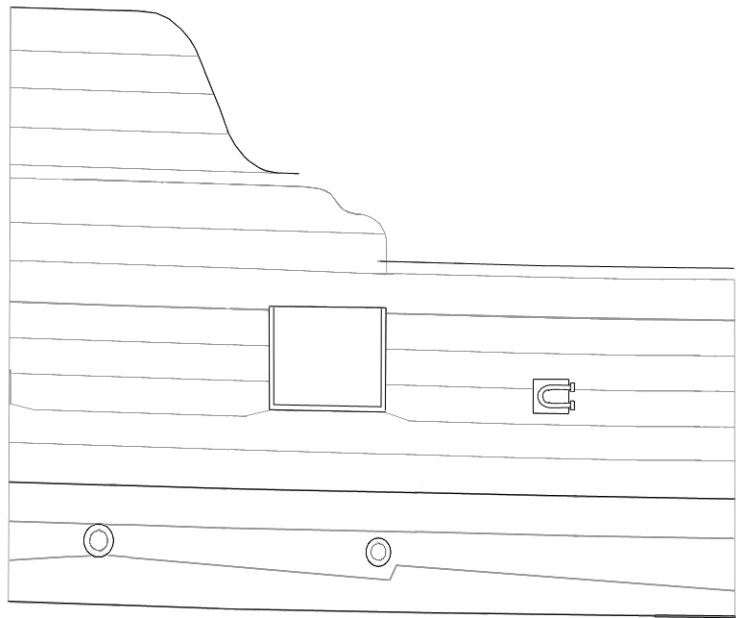

*Sweep port lid and scupper linings, scale 1:48*

Should you go over the edge of the area, a light scrape with a sharp point will remove any excess when thoroughly dry. However, there is a risk of marring the finish of the wale, so care while painting is preferable. Another strategy might be to cut an oval of suitable size in a piece of masking film and apply this to the wale.

## THE SWEEP PORT LID

The gun ports in the waist of the ship are not fitted with lids. However, the sweep ports are fitted with them. Cut a piece of 2" plank to fit the aperture. The hinge is horseshoe-shaped and hinges on the forward side, as shown above.

My own method for making these hinges is to take a piece of soft copper wire and bend it to a U-shape, leaving the ends over-long. Carefully hammer the wire flat on a metal surface. This will also widen the wire. It takes a little practice, but you will get a satisfactory result after a few attempts.

Now take a length of  $\frac{1}{32}$ " diameter brass or copper wire for the hinge knuckles and lay it across the open legs of the U in the correct position, then silver-solder the two pieces together. The wire ends may then be trimmed off and the center section cut away. Cut the legs of the U short and file them flush to the knuckles. Blacken, then epoxy the completed hinge to the lid and install it on the model.

## THE FENDERS

There are two fenders that run up the sides of the ship, spaced 16" apart. They are 3½" wide and shaped to fit the ship's side as illustrated. Your own model may differ slightly, so make up a card template to fit the ship's side first. Some ships have fenders that taper slightly as they descend the side.

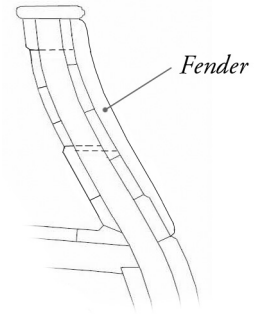

After cutting the fenders, scratch-mold their outer edges with a similar astragal profile to the quarterdeck rails. Attach them to the sides with five bolts each.

## THE PLANKSHEER AND PLANKSHEER RAIL

The planksheer runs along the waist and the ornamental rail below it continues aft over the planking. Notice that the aft end of the planksheer is cut at a 45° angle to meet the hanging piece; the curved section of rail at the hance. The planksheer is 3" thick and of a width to overlap the outer planking by 3". Any overlap inside is problematic: usually there was a gangway from quarter deck to forecastle, but none is specified in the *Echo* contract. *Read the notes on pages 42-43.* If you decide *not* to fit a gangway, then the overlap on the string in the waist should be 2", if you plan to fit a gangway, cut the two mortises into the string in the waist and make the inner edge of the planksheer flush with the string.

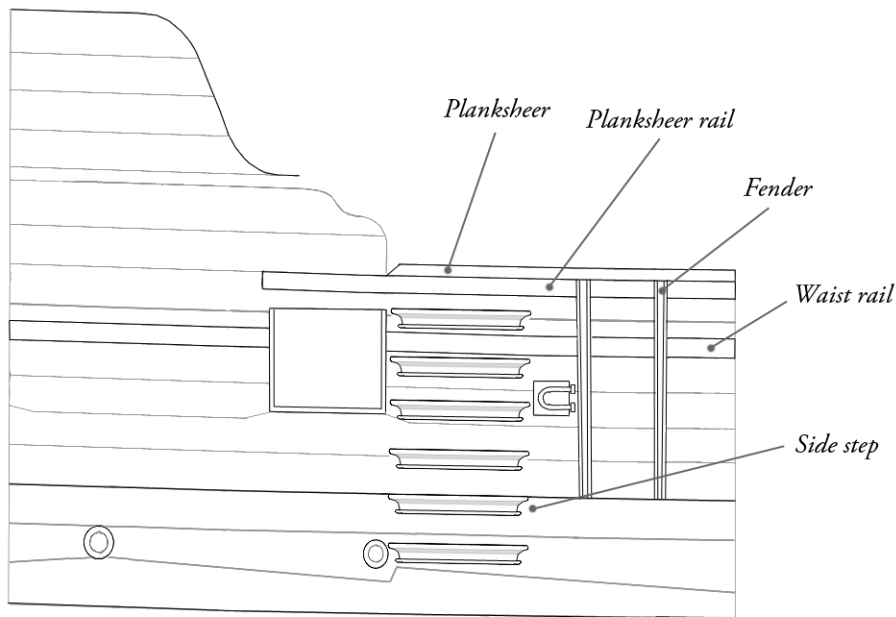

*Sheer and waist rails, planksheer, steps and fenders, scale 1:48*

Overlapping edges are molded with the same astragal section as the quarterdeck breast rails. I recommend you scratch-mold the planksheer before you cut it to length. Also, do not attach this yet!

The planksheer rail is 2½" thick and 4" deep. This molding is quite fancy. If you cannot file as intricate a shape into your scraper as profile *A*, try *B* as a simpler substitute. The trick is not to have a heavy looking rail. I cut wood strip blanks and rubber cement them to a piece of illustration board, then scrape the profile. The board limits the depth of cut so that the molding is consistent along its length. Moldings on ships of this era were fairly standard, so once you have cut a profile scraper you can use it for subsequent models.

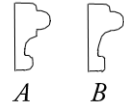

Cut and fit the rail carefully around the fenders. Make the junctions as neat and tight as you can; avoid any gaps here! Also, make sure that the rail follows the sheer curve of the planking below it exactly. A smooth curve here can make or mar the appearance of a model. Note its termination aft, just past the gun port below. This is where the main channel will be located.

#### THE WAIST RAIL

This rail runs below and parallel to the planksheer rail as shown opposite. It is 5" wide and 2½" thick. Its profile is similar to that of the planksheer rail. All the comments above apply here as well when making and fitting this rail. The ends at the gun port are cut flush with the outside plank.

#### THE ENTRY STEPS

There are six steps placed equidistantly up each side. They are cut from 5" square section stock. Their profile is shown on the drawing opposite. I suggest scratch-molding a long strip of wood and cutting off 3' 0" lengths. Make sure that this will fit comfortably between the edge of the port and sweep port. If, not, shorten the steps slightly. The ends will need to be shaped individually using files.

As the steps are attached to a surface of varying curvature, each step will need its inboard face to be cut or sanded at a different angle so that the upper surface is horizontal. The lowest two steps over the wale will need to be dyed or painted to match the wale if it had been blackened. (See also page 45.)

#### THE MAIN CHANNEL

We now come to more challenging work: that of the main channel, chains and deadeyes. The main channel (or, to be more precise, the fore part of it) attaches to the ship's side at the level of the planksheer rail.

The main channel is 1' 6" wide and 4" thick at its inboard edge. The channel tapers across its width to 2½" at the outboard edge. Its shape in plan view may be taken from the drawing here. Check that the length matches your model. Cut it a little over-length for the moment. The inner edge will need to be bevelled slightly so that the channel is horizontal. Note that very little of the channel rests against the ship's side. The 2" air space minimizes the possibility of rot. The places where it does touch are where bolts pass through. I use stub wire in blind holes to do this, rather than true through-bolts.

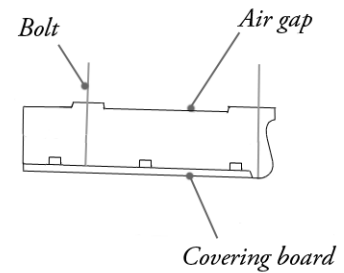

*Main channel, scale 1:48*

Along the outer edge is a 2" wide covering board. This needs to be made now and temporarily fitted. Note the angled end. It is not installed, though, until the chains are in place. However, the scratch molding along the edge, which continues around the end of the channel, needs to be cut now.

Attach the covering board by spot gluing it to the channel blank, then drilling small holes at intervals for two or three treenails. This will ensure the board repositions accurately. Now sand the taper across the channel until the outer edge is 2½" thick. Refine the serpentine shape of the end. The molding runs along the edge of the covering board and around the end of the channel, terminating at the point where the curve ends. The usual astragal section is scraped along the edge. Now cut the channel and covering board to exact length.

Carefully remove the covering board and set it aside in a safe spot. As one proceeds aft along the channel, the chains become more angled. However, the foremost chains are reasonably vertical, so the slots do not really need to be cut at an angle. Drill the inboard side for stub pieces of 1/32" brass rod and insert two pieces. They should protrude about 3/16". Carefully mark the positions of the pins on the side of the model and drill in horizontally without breaking through the inner planking. Done accurately, the channel should locate in the correct position and sit horizontally.

## DEADEYES

There are three to be made for each side. These are 10" in diameter. One could use commercial ones: 5mm diameter is about right. Otherwise, turn and drill them yourself to standard proportions. The holes, 1¼" in diameter, are ¼ of the deadeye diameter in from the edge. The thickness is one inch more than half the diameter; in this case it is 6".

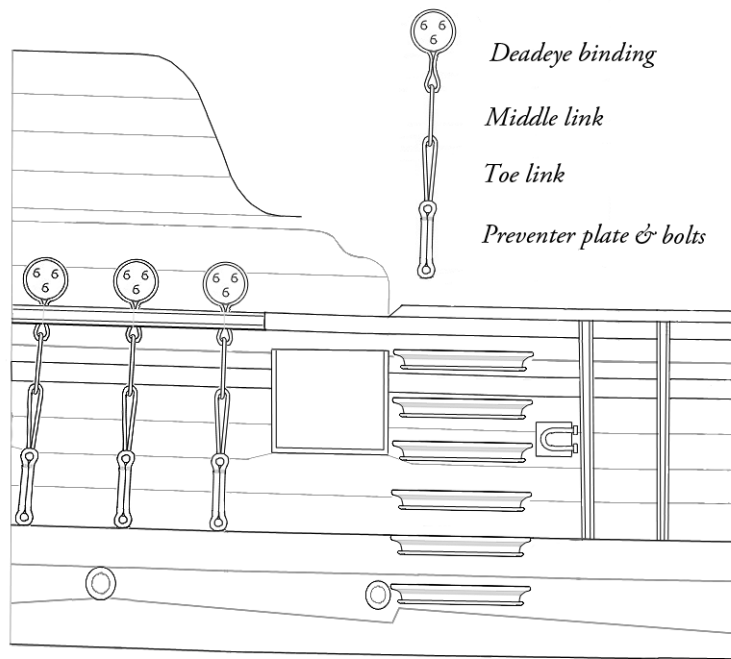
*Main chains, scale 1:48*

### THE MAIN CHAINS

These are comprised of the deadeye bindings, middle links, toe links and preventer plates (illustrated above). The three links are of 1¼" diameter iron. Begin with the deadeye binding. Use a piece of softened wire to find the length required to produce the binding with a loop below of the size illustrated. From this circumferential length, one can calculate the diameter of mandrel on which to wind wire for bindings. Process the wire and silver solder the rings as you did for the ringbolts (page 30). Do not install the deadeyes in them yet.

Carry out the same procedure for the toe links. Remember that they appear somewhat foreshortened in the drawing above. Finally, the middle links need to be made. To do this, temporarily install a toe link on a bolt to the side of the ship. Slip a deadeye temporarily into a binding and squeeze this closed using a pair of needle-nose pliers. Now install the binding in the channel. Bend the toe link and binding so that they align. You can now find the size of middle link required to give the correct overall length to the chain. Make sure that the bends in the trial link are snug to the adjacent links and that the sides of the link are straight and it is not an oval shape. Again, calculate the mandrel size needed to wind the middle link wire around. Cut and shape the links and thread a toe link and a binding on each middle link before soldering it closed. Blacken the assembly in the usual way.

## THE PREVENTER PLATES

These will need to be cut from brass or copper sheet. I haven't tried it myself, but suppose one could use styrene sheet. In the real ship these were not actually plates, but were smithed from square section iron bar. The sheet material should be about  $\frac{1}{32}$ " thick, or a little less. Note that there is a cranked section near the upper end to accommodate the toe link beneath the plate. Use the drawing on the previous page as a guide, but allow a little additional length for the crank.

Drill the ends for the bolts and score with a sharp blade between the holes to simulate the appearance of iron bar material. Blacken as usual.

For bolts, I use round-headed rivets with a head diameter of about 0.8mm.<sup>1</sup> In the real ship, these bolts pass all the way through the ship's side and forelock on the spirketting. One could simulate the forelocked bolt ends as for the other through bolts. However, I have not seen this done in a model. Use the plan on the previous page as a guide to the angles of the chains.

Finally, install the covering board permanently on the channel over the chains.

## THE DRIFT AND HANCE

The next challenge is to make the drift and the ornamental volute or scroll. First let's tackle the drift. This is a piece of rail that curves around by about 90° (see below). It is 3" thick. The finished width is the same as the planksheer in the waist, if the latter is molded on both edges. As the ship's side is not quite vertical here, you will need to cut an over-width blank to begin. Cut the curved profile on a scroll-saw, keeping the grain running on the diagonal. Fit the piece to the bulwark, cutting the end diagonally to meet the planksheer. (This is most easily done while the planksheer is loose.) When you

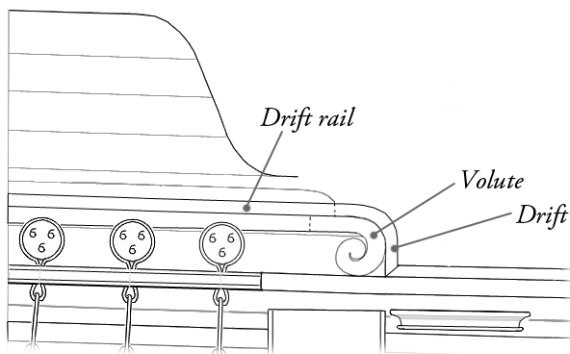

*Drift rail and volute, scale 1:48*

are satisfied that it sits well on the frames and plank, run your pencil under the lip along the planking inside and out. This will give you a guide for shaping the edges. Add the necessary amount inboard and out, then shape the drift piece. To scratch mold it, stop slightly short of the 45° angle and shape the last bit with files. This way you will not break the corner off. Finally, trim the aft end. Drift and planksheer may then be stained or dyed and fixed in place.

<sup>1</sup> One current source (2015) for miniature hardware is Scale Hardware, [www.scalehardware.com](http://www.scalehardware.com)



## THE VOLUTE AND DRIFT RAIL

This is, perhaps, your biggest challenge unless you are already a carver. Trace the outline of the volute from the plan on the previous page. Ensure that the depth is correct, so that the lowest point will sit on the plank-sheer rail and the top will sit comfortably under the hancing piece. If not, adjust the pattern accordingly. Note that the aft end is extended so that the joint will be staggered relative to the drift rail above. Make sure that the tail is 4" wide.

Once the pattern is satisfactory, cut the blank from 2¼" thick stock. Again, run the grain diagonally. Make the end of the straight section overlength. You will trim it after creating the molding. Glue the blank to a piece of illustration board before proceeding. You now need to make yet another scratch molding profile similar to the pattern here or the example below. It should be 4" wide and just over 2" deep. Scratch-mold the straight section of the volute. This gives you a good start for the curved section.



If you study the photograph at the right, you will see that the molding deepens slightly as it curves around and then ends in a button that is the full height of the blank. Carefully extend the molded section into the curve using a very small, well-sharpened gouge of suitable shape. Work very slowly and in shallow, incremental cuts. Refine things with a sharp point and you should get a satisfactory result. Carefully

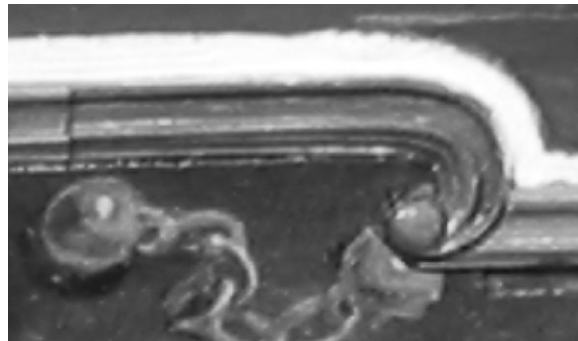

separate the completed molding from the illustration board and clean up the back. Trim the aft end neatly and glue it in position.

The drift molding is also 4" wide and 2¼" thick. Scratch mold a length using the same scraper as for the hance. Trim and fit, then glue it in place.

Immediately above the molding is the drift rail. This is a continuation of the drift. Cut a piece of stock 3" wide and the depth of the drift's overlap outboard. Scrape the molding to match the drift in the usual way, cut the ends neatly to length and glue it above the drift molding.

## THE PLANKSHEER, CONTINUED

The planksheer continues above the hance, as shown in the drawing below. It is a vestige of its former self, which was a full width planksheer before the quarter deck bulwark was raised and boarded up. For most of its length here, it is simply an ornament. The end of it terminates in a small ornamental scroll. The process for making the scroll is the same as for the drift. This time the depth of the planksheer is 2½". It will overlap the planking outboard and inboard by 2". Its profile will be a simple half-round.

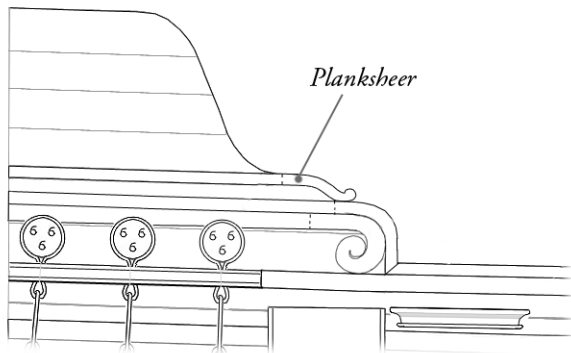

*Planksheer, scale 1:48*

Cut the scroll section on the scrollsaw to the shape at left and fit it to the top of the bulwark. The latter may need a little filing down so that there is no gap between it and the scroll. Make as neat a job of this as you can. Once satisfied, scratch mold the edges and trim the aft end before finishing (if you wish) by blackening the piece and then installing it on the model. The aft section of planksheer is 2½" wide and 2" deep. Mold the edge as usual, finish, blacken if appropriate and install it on the model.

## THE ROUGHTREE RAIL

This is the last of the rails to make. Once again, the procedure for making it is the same as before. There is a long, curved section that will need to fit accurately over the raw end of the bulwark. This time it will be easiest to trace the contour directly from your model to get the correct shape. The width of the rail should be sufficient to overlap the top of the bulwark by 2" each side and the edges molded to a half-round. Once again, finish this rail to taste before fixing it permanently to your model.

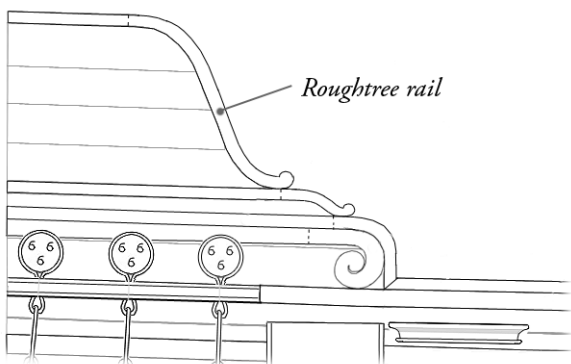

*Roughtree rail, scale 1:48*

This should complete your cross-sectional model. However, there is a discrepancy between the contract for the ship and the recorded plans. There is no mention in the *Echo* contract of a fixed gangway and gangway. However, these are clearly shown on the 'as built' deck plan ZAZ3840. For those that wish to add this feature, details follow.

THE FIXED GANGWAY

As mentioned, this is delineated on the plan of the quarter deck. It is a step down from that level, and continues forward to meet the forecastle. Of course, only the aftermost portion of this will be represented on your model. There is an underlying framing to this feature. The framing scheme given here is conjectural.

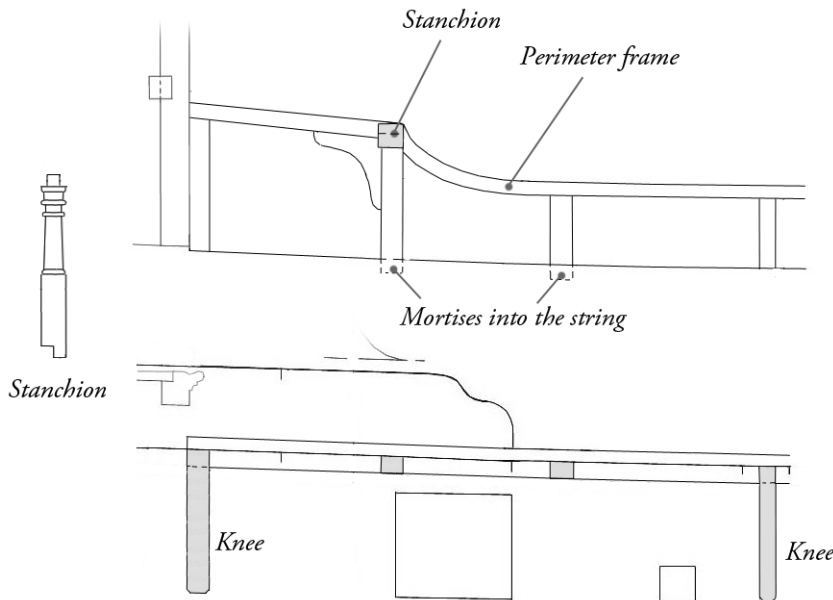

*Fixed part of the gangway, scale 1:48*

There is a perimeter frame supported by two wood knees. At this time period wood was being replaced by iron knees, so this might also be a choice. There are two very short beams that tenon into the string in the waist. Note that both beams and knees should follow the round-up of the quarter deck, as the planking above is not horizontal. The planks' upper surface needs to be flush with the top of the planksheer, so measure down 3" from the top of the planksheer. You may take measurements from the drawing above, but

double-check that this fits your model before committing to wood. For the knees, first make card patterns to fit the inside of the bulwark exactly. The lower ends of the vertical arms of the knees come down to meet the top edge of the spirketting.

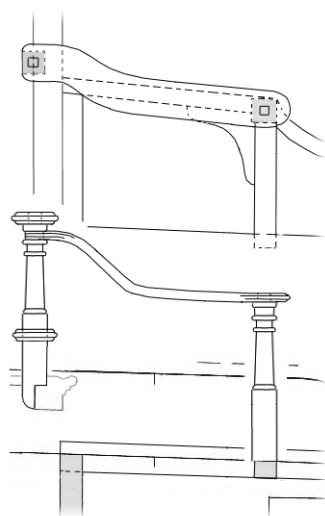

*Gangway hand rail*

There is a stanchion for a handrail that tenons or half-joints into the perimeter frame and beam. It is similar to the quarter deck stanchions that you made earlier. Either way, make sure that it stands vertically.

The hand rail (left) is a tricky piece to make, as it curves in two planes. Perhaps the easiest strategy is to cut it on the scrollsaw from solid. The edges are astragal molded as usual. Note that the upper end is forked around the outer stanchion of the quarterdeck breastwork and the lower,

forward end is mortised for the stanchion there. On some ships this item was made of wrought iron strap. Delay installing stanchion or rail permanently until the gangway is planked.

### THE GANGWAY PLANKING

In *Echo*, the fixed part of the gangway is continuous with the gangway proper. In many ships there was a further step down. In this case the planking is fairly simple to lay.

There is a margin plank that overlaps the framing by 2". The inboard edge should be a half-round. All the planks are 3" thick to abut and be flush with the planksheer. The drawing (right) should be self-explanatory. The nominal planking width of the gangway is 9".

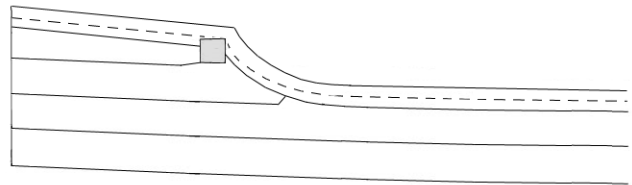

*Gangway planking, scale 1:48*

### LADDERWAY TO THE UPPER DECK

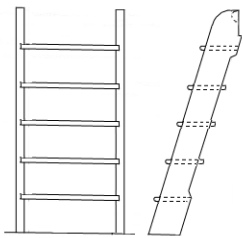

*Ladderway, scale 1:48*

There is a ladder descending from the gangway to the upper deck. The scantlings for this are not specified in the contract. It has five rungs approximately 9" apart. The ladderway is 2' 3" wide overall. The styles (side rails) are 2" thick and the treads are 1" thick. Check the overall height from your model before building the ladderway to the drawing at left. The tops of the styles should be level with the top of the gangway. You will need to notch the nosing of the gangway to fit the ladder (see below). As the ladder sits on a slightly sloping deck and the styles need to be vertical, the ladder will need to be slightly racked after assembly.

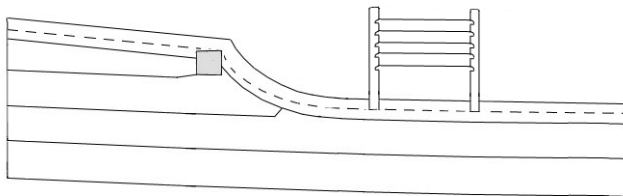

*Ladderway plan, scale 1:48*

The ladder can be constructed by any of the usual methods. Make and groove the styles first, then cut treads of identical width, noting that the tread ends are not quite at right angles. I usually glue the treads into one style, then line them up for the second style. I squeeze the assembly gently in a vise to ensure all the treads are fully home in their grooves.

Unless you are fitting guns on the upper deck, this completes your cross-sectional model. Now is the time to sit back and enjoy the results of your work. Having gone through all the steps in this booklet should give you both the sense of the amount of work required to complete a full hull model, and also the confidence to tackle such a project.

PAINT NOTES

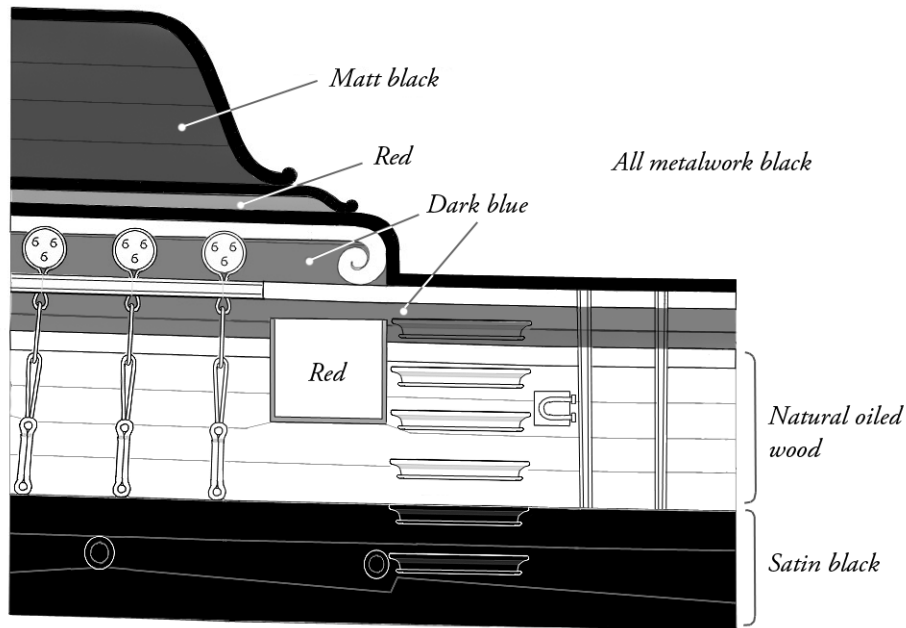

*Typical color scheme, scale 1:48*

During this time period part of the sides of the ship were painted. A typical paint scheme is shown below. Occasionally black was substituted for dark blue. Planking below the wale and above the waterline was natural oiled wood and the bottom planking was coppered. If you are not coppering the bottom, then either leave the exposed planking in natural wood or paint it off-white to represent anti-fouling 'white stuff'. The planksheer, drift rail and roughtree rail may be painted or dyed and polished to a satin black finish.





